

the better way to heat

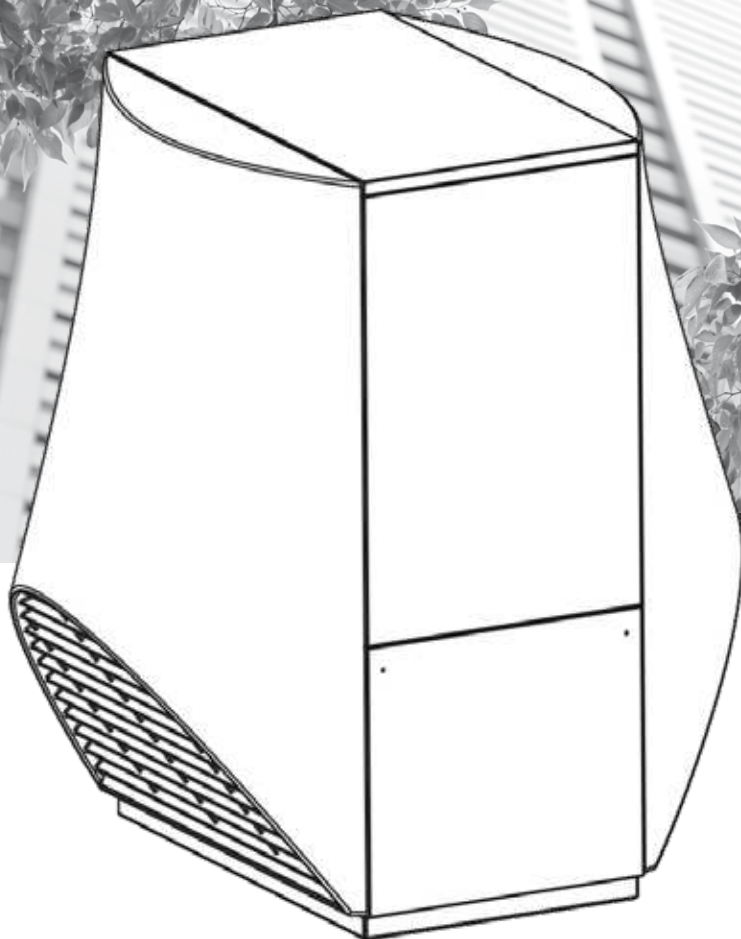
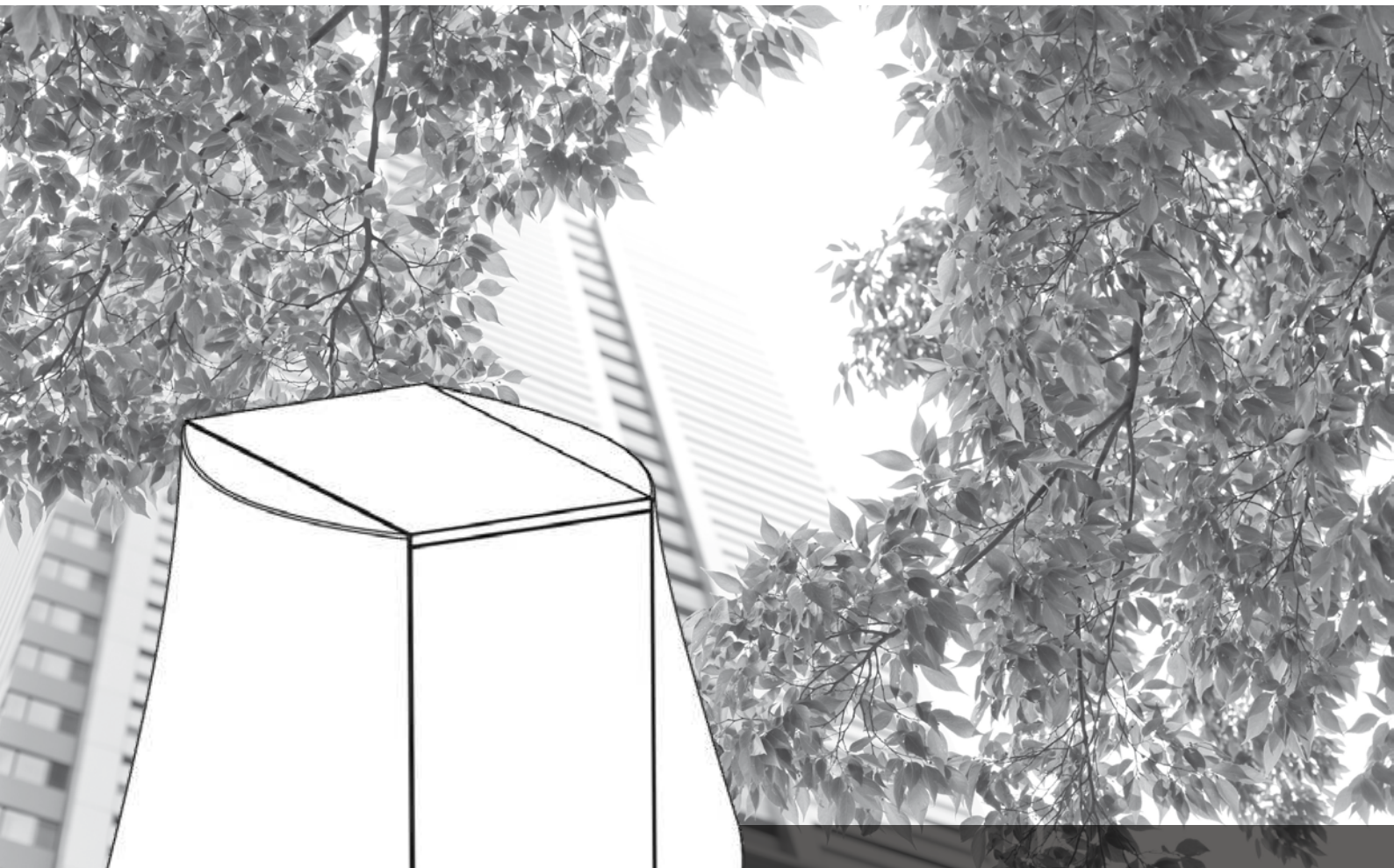

Air/Water Heat Pumps
Outdoor Installation

Operating Manual

LW A series

83054200hUK – Translation into English of the original German operating manual





Please read first

This operating manual provides important information on the handling of the unit. It is an integral part of the product and must be stored so that it is accessible in the immediate vicinity of the unit. It must remain available throughout the entire service life of the unit. It must be handed over to subsequent owners or operators of the unit.

Read the operating manual before working on or operating the unit. This applies in particular to the chapter on safety. Always follow all instructions completely and without restrictions.

It is possible that this operating manual may contain instructions that seem incomprehensible or unclear. In case of questions or uncertainty, contact the factory customer service department or the manufacturer's local service partner.

Since this operating manual was written for several different models of the unit, always comply with the parameters for the respective model.

This operating manual is intended only for persons assigned to work on or operate the unit. Treat all constituent parts confidentially. The information contained herein is protected by copyright. No part of this operating manual may be reproduced, transmitted, copied, stored in electronic data systems or translated into another language, either wholly or in part, without the express written permission of the manufacturer.

Symbols

The following symbols are used in the operating manual. They have the following meaning:



Information for users.



Information or instructions for qualified technicians.



DANGER

Indicates a direct impending danger resulting in severe injuries or death.



WARNING

Indicates a possibly dangerous situation that could result in severe injuries or death.



CAUTION

Indicates a possibly dangerous situation that could result in medium or light injuries.



ATTENTION

Indicates a possibly dangerous situation, which could result in property damage.



NOTICE

Emphasized information.



ENERGY SAVING TIP

Indicates suggestions that help to save energy, raw materials and costs.



Reference to other sections of the operating manual.



Reference to other instructions of the manufacturer.



Contents



INFORMATION FOR USERS AND QUALIFIED PERSONNEL

PLEASE READ FIRST	2
SYMBOLS	2
INTENDED USE	4
EXCLUSION OF LIABILITY	4
EC CONFORMITY	4
SAFETY	4
CUSTOMER SERVICE	5
WARRANTY / GUARANTEE	5
DISPOSAL	5
OPERATING PRINCIPLE OF HEAT PUMPS	6
AREA OF UTILIZATION	6
HEAT QUANTITY RECORDING	6
OPERATION	6
CARE OF THE UNIT	7
MAINTENANCE OF THE UNIT	7
Cleaning and rinsing of unit components	7
MALFUNCTIONS	7



INSTRUCTIONS FOR QUALIFIED TECHNICIANS

SCOPE OF DELIVERY	8
INSTALLATION AND ASSEMBLY	9
Installation location	9
Transport to installation location	9
Sound	10
Installation	13
Attaching the air flow baffles	15
Installation / connection to heating circuit	17
Condensate discharge	19
PRESSURE RELIEF	19
OVERFLOW VALVE	19
BUFFER TANK	19
CIRCULATING PUMPS	19
WATER HEATING	19
HOT-WATER TANK	20
ELECTRICAL CONNECTIONS	20
RINSING, FILLING AND BLEEDING THE SYSTEM	23
Water quality of the fill and additional water in hot water heating systems	23
INSULATING THE HYDRAULIC CONNECTIONS	25
SET THE OVERFLOW VALVE	25
COMMISSIONING	26
Safety temperature limiter	26

DISMANTLING	27
TECHNICAL DATA / SCOPE OF DELIVERY	
LW 71A – LW 121A	28
LW 140A – LW 310A	30
PERFORMANCE CURVES	
LW 71A	32
LW 81A	33
LW 101A	34
LW 121A	35
LW 140A	36
LW 180A	37
LW 251A	38
LW 310A	39
DIMENSIONAL DRAWINGS	
LW 71A – LW 81A	40
LW 101A	41
LW 121A	42
LW 140A – LW 180A	43
LW 251A	44
LW 310A	45
INSTALLATION PLANS	
LW 71A – LW 81A	46
LW 101A	47
LW 121A	48
LW 140A – LW 180A	49
LW 251A	50
LW 310A	51
HYDRAULIC INTEGRATION	
LW 71A – LW 251A	
Row tank	52
Separate buffer tank	53
LW 310A	
Row tank	54
Separate buffer tank	55
Legend Hydraulic integration	56
TERMINAL DIAGRAMS	
LW 71A – LW 81A	57
LW 101A – LW 251A	58
LW 310A	59
CIRCUIT DIAGRAMS	
LW 71A – LW 81A	60
LW 101A – LW 121A	62
LW 140A	64
LW 180A	66
LW 251A	68
LW 310A	71
EC DECLARATION OF CONFORMITY	75



Intended use

The unit may be used only for the intended use. This means:

- for heating.
- for heating hot water.

The unit may be operated only within its technical parameters.



Overview “Technical data/scope of delivery”.



NOTICE

Notify the responsible power supply company of the use of a heat pump or heat pump system.



CAUTION

The unit is not suitable for use in IT network systems.

Exclusion of liability

The manufacturer will not be liable for damage resulting from unauthorized use of the unit.

The manufacturer's liability will also be voided in the following cases:

- if work is performed on the unit and its components in a manner that does not comply with the terms of this operating manual;
- if work is performed on the unit and its components in an improper manner;
- if work is performed on the unit that is not described in this operating manual, and this work was not expressly approved in writing by the manufacturer;
- if the unit or components in the unit are modified, redesigned or removed without the express written permission of the manufacturer.

EC conformity

The unit bears the CE mark of conformity.



EC declaration of conformity

Safety

The unit is operationally safe when used for the intended purpose. The construction and design of the unit conform to the state of the art, all relevant DIN/VDE regulations and all relevant safety regulations.

Every person who performs work on the unit must have read and understood the operating manual prior to starting any work. This also applies if the respective person has already worked with such a unit or a similar unit or has been trained by the manufacturer.

Every person who performs work on the unit must comply with the applicable accident prevention and safety regulations. This applies in particular to the wearing of personal safety gear.



DANGER

Danger of fatal injury due to electric current!

Electrical connections may be installed only by qualified electricians.

Before opening the unit, disconnect the system from the power supply and secure it from being switched back on!



ATTENTION

If using the unit in 3~230V systems, please note that the residual-current circuit breaker (RCCB) used must be AC-DC sensitive.



WARNING

Only qualified technicians (trained heating, cooling and electrical technicians) may perform work on the unit and its components.



WARNING

Observe safety labels on and in the unit.



WARNING

**Unit contains refrigerants!
Leaking refrigerant could result in personal injury or material damage. Therefore:**

- **Shut down unit.**
- **Notify the manufacturer's authorized service center.**



! **ATTENTION**

For safety reasons:

Never disconnect the unit from the power supply, unless the unit is being opened.

! **ATTENTION**

Install the heat pump only outdoors and operate only with outside air as the heat source. Do not restrict or block the air-conducting sides.



Dimensional drawing and installation plan for respective unit model.



WARNING

Never switch on unit if air flow baffles on the unit are removed.

! **ATTENTION**

The integration of the heat pump in ventilation systems is not permissible. The use of the cooled air for cooling purposes is not permitted.

! **ATTENTION**

The ambient air in the location where the heating pump is installed and also the intake air which is used as a source of heat must not contain any kind of corrosive components!

Components such as ammonia, sulphur, chlorine, salt, sewer gas, flue gases etc. may cause damage leading to complete failure or even a total write-off of the heating pump!



CAUTION

In the air outlet area the air temperature is ca. 5 K below the ambient temperature. Under certain climatic conditions, therefore, an ice layer can form in the air outlet area. Install the heat pump so that the air blower does not blow in the direction of footpaths.

Customer service

For technical assistance, please contact your qualified technician or the manufacturer's local service partner.

For a current list and additional partners of the manufacturer, please visit

DE: www.alpha-innotec.de

EU: www.alpha-innotec.com

Warranty / Guarantee

For warranty and guarantee conditions, please refer to the purchase documents.



NOTICE

Please contact your dealer concerning warranties and guarantees.

Disposal

When decommissioning the unit, always comply with applicable laws, directives and standards for the recovery, recycling and disposal of materials and components of cooling units.



“Dismantling”.



Operating principle of heat pumps

Heat pumps operate on the principle of a refrigerator: the same technology, only with the opposite effect. The refrigerator extracts heat from foods, which is released into the room through fins on the back.

The heat pump extracts heat from our environment: air, earth or water. The extracted heat is conditioned in the unit and supplied to the heating water. Even when it is extremely cold outside, the heat pump draws enough heat to heat a house.

Example: drawing of a brine/water heat pump with floor heating:

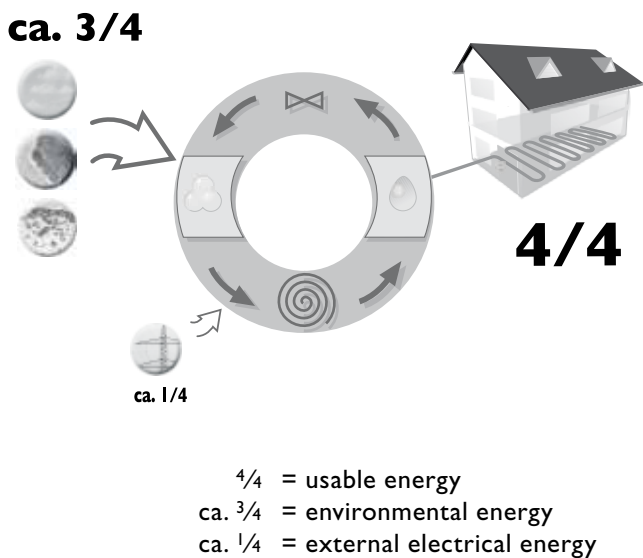

Area of utilization

Taking into consideration the ambient conditions, limits of application and the applicable regulations, every heat pump can be utilized in new or existing heating systems.

Overview "Technical data/scope of delivery".

Heat quantity recording

In addition to the proof of the unit's efficiency, EEWaermeGalso meets the demand for a heat quantity recording (hereafter referred to as HQR). The HQR is mandatory with air/water heat pumps. With brine/water and water/water heat pumps, a HQR may only be set up when a forward flow temperature of $\geq 35^\circ\text{C}$ has been reached. The HQR must record the total warm energy release (heating and hot water) in the building. In heat pumps with heat quantity recording, the analysis is conducted by the regulator. The regulator displays the thermal energy that is exchanged from the heating system in kWh.

Operation

Your decision to purchase a heat pump or a heat pump system is a long-term contribution to protecting the environment through low emissions and reduced primary energy use.

You can operate and control the heat pump system with the control element of the heating and heat pump regulator.



NOTICE

Make sure that the control settings are correct.



Operating manual of the heating and heat pump regulator.

To ensure that your heat pump or heat pump system operates efficiently and ecologically, the following are especially important:



ENERGY SAVING TIP

Avoid unnecessarily high flow temperatures. A lower flow temperature on the hot water side increases the efficiency of the system.



ENERGY SAVING TIP

When letting in fresh air, do not leave windows open for an extended period, thus saving energy and reducing your heating costs.



Care of the unit

The outer surfaces of the unit can be cleaned with a damp cloth and household cleaning products.

Do not use cleaning or care products that contain abrasives, acids and/or chlorine. Such products would destroy the surfaces and could also damage the technical components of the unit.

Maintenance of the unit

The cooling circuit of the heat pump requires no regular maintenance.

According to EU regulation (EC) 517/2014, leak inspections and maintenance of a log book are required by law for certain heat pumps!



Log book for heat pumps, Section "Information on use of the log book".

The components of the heating circuit and the heat source (valves, expansion vessels, circulating pumps, filters, dirt traps) should be inspected as well as cleaned as needed - at the very least annually - by a qualified heating or cooling system technician.

The intake and blow-out openings must be inspected for dirt at regular intervals (depending on the installation location) and cleaned, if necessary.

! ATTENTION

Check regularly to ensure that the condensate can drain out of the unit unobstructed. To this end, regularly check the condensate pan in the unit and the condensate drain to ensure that they are clean / free from obstructions and clean as needed.

Icing of the protective grating

When temperatures fall below freezing and high levels of humidity are present, ice can form on the protective grating of the air flow baffles. In order to ensure problem-free operations, the ice must be removed on a regular basis.

It is a good idea to have a maintenance contract with a heating installation company. The company will conduct the required maintenance at regular intervals.

CLEANING AND RINSING OF UNIT COMPONENTS



CAUTION

Unit components may be cleaned and rinsed only by customer service personnel authorized by the manufacturer. Use only liquids recommended by the manufacturer.

Rinsing of the liquefier with chemical cleaning agents must be followed by neutralization of residue and intensive rinsing with water. Always observe the technical data of the manufacturer of the heat exchanger.

Malfunctions

In the event of a malfunction, you can detect the cause of the malfunction via the diagnostic program of the heating and heat pump regulator.



Operating manual of the heating and heat pump regulator.



WARNING

Service and repair work on the components of the unit may be performed only by customer service personnel authorized by the manufacturer.

Note that no malfunction is displayed if the safety temperature limiter on the electric heating element has been triggered (depending on unit model).



"Commissioning", "Safety temperature limiter" section.



Scope of delivery

Example of scope of delivery:

LW 71... / LW 81...(ONE PACKING UNIT):



Compact unit with fully hermetically enclosed compressor, all safety-related components for monitoring of cooling circuit and hose for condensate discharge.

LW 101... THROUGH LW 310...
(TWO PACKING UNITS):

Packing unit I:



Air flow baffles (quantity of 2, each in a separate box)

Packing unit 2:



Basis unit (this illustration shows an example LW 121...) with fully hermetically enclosed compressor, all safety-related components for monitoring of cooling circuit and hose for condensate discharge (connected on heat pump side).

- ① Inspect delivery for outwardly visible signs of damage...
- ② Check to make sure that delivery is complete... Any defects or incorrect deliveries must be claimed immediately.



NOTICE

Note the model.



Overview "Technical data/scope of delivery".

ACCESSORIES NECESSARY FOR OPERATION



ATTENTION

Use only original accessories from the manufacturer of the unit.

Heating and heat pump controllers, as wall-mounted controllers or integrated in the hydraulic tower (for output range 7 – 18kW), as well as control and sensor cables, are functionally necessary accessories, which you must order separately.



The heat pump is a functioning unit only with the heating and heat pump regulator and the control and sensor wires.



Heating and heat pump regulator
(for wall mounting)

Control and sensor wires are available in various lengths, as required.

ADDITIONAL ACCESSORIES

The installation accessories (vibration decouplers) for air/water outdoor installation heat pumps must be ordered separately.

With the LW 310A, you must select the electrical heating element for the specific system and order it separately.

Installation and assembly

Observe the following when performing all work:



NOTICE

Always comply with applicable accident prevention regulations, statutory regulations, ordinances and directives.



NOTICE

Observe the sound levels of the respective model.



Overview “Technical data/scope of delivery”, “Sound” section.

INSTALLATION LOCATION



ATTENTION

Install the unit only outdoors.



Dimensional drawing and installation plan for respective unit model.

TRANSPORT TO INSTALLATION LOCATION

To prevent damage during transport, always transport the unit to final installation location in its original packaging, using a lifting truck, forklift or crane.



WARNING

Several people are required to transport the unit. Do not underestimate the weight of the unit.



Overview “Technical data/scope of delivery”, “General unit data” section.



WARNING

Unit is not fastened to the wooden pallet. Danger of tipping over during transport! This can result in personal injury and damage to the unit.

- Take suitable precautionary measures to eliminate the danger of tipping.



ATTENTION

Never use components and hydraulic connections on the unit for purposes of transport.



ATTENTION

Do not tilt the unit more than a maximum of 45° (in any direction).



SOUND

The noise emission from the heat pumps must be taken into account in the respective installation plans for air / water heat pumps. The respective regional regulations must be complied with.



NOTE.

The following sound pressure levels are calculated values. Other constellations, adjoining other buildings or even reflecting surfaces may lead to a level increase. An exact specification of each sound pressure level is possible only through a measurement spot when the heat pump is already installed.

The following sound pressure levels result, depending on the distance and installation variant with directivity factor Q. (page 12):

LW 71A	Distance from the heat pump in m																			
	1	2	3	4	5	6	7	8	9	10	11	12	13	14	15	16	17	18	19	20
Directivity factor	Sound pressure level at max. heating output in dB(A)																			
Q																				
2	53	47	43,5	41	39	37,4	36,1	34,9	33,9	33	32,2	31,4	30,7	30,1	29,5	28,9	28,4	27,9	27,4	27
4	56	50	46,5	44	42	40,4	39,1	37,9	36,9	36	35,2	34,4	33,7	33,1	32,5	31,9	31,4	30,9	30,4	30
8	59	53	49,5	47	45	43,4	32,1	40,9	39,9	39	38,2	37,4	36,7	36,1	35,5	34,9	34,4	33,9	33,4	33

LW 81A	Distance from the heat pump in m																			
	1	2	3	4	5	6	7	8	9	10	11	12	13	14	15	16	17	18	19	20
Directivity factor	Sound pressure level at max. heating output in dB(A)																			
Q																				
2	53	47	43,5	41	39	37,4	36,1	34,9	33,9	33	32,2	31,4	30,7	30,1	29,5	28,9	28,4	27,9	27,4	27
4	56	50	46,5	44	42	40,4	39,1	37,9	36,9	36	35,2	34,4	33,7	33,1	32,5	31,9	31,4	30,9	30,4	30
8	59	53	49,5	47	45	43,4	32,1	40,9	39,9	39	38,2	37,4	36,7	36,1	35,5	34,9	34,4	33,9	33,4	33

LW 101A	Distance from the heat pump in m																			
	1	2	3	4	5	6	7	8	9	10	11	12	13	14	15	16	17	18	19	20
Directivity factor	Sound pressure level at max. heating output in dB(A)																			
Q																				
2	53	47	43,5	41	39	37,4	36,1	34,9	33,9	33	32,2	31,4	30,7	30,1	29,5	28,9	28,4	27,9	27,4	27
4	56	50	46,5	44	42	40,4	39,1	37,9	36,9	36	35,2	34,4	33,7	33,1	32,5	31,9	31,4	30,9	30,4	30
8	59	53	49,5	47	45	43,4	32,1	40,9	39,9	39	38,2	37,4	36,7	36,1	35,5	34,9	34,4	33,9	33,4	33

LW 121A	Distance from the heat pump in m																			
	1	2	3	4	5	6	7	8	9	10	11	12	13	14	15	16	17	18	19	20
Directivity factor	Sound pressure level at max. heating output in dB(A)																			
Q																				
2	56	50	46,5	44	42	40,4	39,1	37,9	36,9	36	35,2	34,4	33,7	33,1	32,5	31,9	31,4	30,9	30,4	30
4	59	53	49,5	47	45	43,4	42,1	40,9	39,9	39	38,2	37,4	36,7	36,1	35,5	34,9	34,4	33,9	33,4	33
8	62	56	52,5	50	48	46,4	45,1	43,9	42,9	42	41,2	40,4	39,7	39,1	38,5	37,9	37,4	36,9	36,4	36



LW 140A	Distance from the heat pump in m																			
	1	2	3	4	5	6	7	8	9	10	11	12	13	14	15	16	17	18	19	20
Directivity factor	Sound pressure level at max. heating output in dB(A)																			
Q																				
2	53	47	43,5	41	39	37,4	36,1	34,9	33,9	33	32,2	31,4	30,7	30,1	29,5	28,9	28,4	27,9	27,4	27
4	56	50	46,5	44	42	40,4	39,1	37,9	36,9	36	35,2	34,4	33,7	33,1	32,5	31,9	31,4	30,9	30,4	30
8	59	53	49,5	47	45	43,4	32,1	40,9	39,9	39	38,2	37,4	36,7	36,1	35,5	34,9	34,4	33,9	33,4	33

LW 180A	Distance from the heat pump in m																			
	1	2	3	4	5	6	7	8	9	10	11	12	13	14	15	16	17	18	19	20
Directivity factor	Sound pressure level at max. heating output in dB(A)																			
Q																				
2	55	49	45,5	43	41	39,4	38,1	36,9	35,9	35	34,2	33,4	32,7	32,1	31,5	30,9	30,4	29,9	29,4	29
4	58	52	48,5	46	44	42,4	41,1	39,9	38,9	38	37,2	36,4	35,7	35,1	34,5	33,9	33,4	32,9	32,4	32
8	61	55	51,5	49	47	45,4	44,1	42,9	41,9	41	40,2	39,4	38,7	38,1	37,5	36,9	36,4	35,9	35,4	35

LW 251A	Distance from the heat pump in m																			
	1	2	3	4	5	6	7	8	9	10	11	12	13	14	15	16	17	18	19	20
Directivity factor	Sound pressure level at max. heating output in dB(A)																			
Q																				
2	60	54	50,5	48	46	44,4	43,1	41,9	40,9	40	39,2	38,4	37,7	37,1	36,5	35,9	35,4	34,9	34,4	34
4	63	57	53,5	51	49	47,4	46,1	44,9	43,9	43	42,2	41,4	40,7	40,1	39,5	38,9	38,4	37,9	37,4	37
8	66	60	56,5	54	52	50,4	49,1	47,9	46,9	46	45,2	44,4	43,7	43,1	42,5	41,9	41,4	40,9	40,4	40

LW 310A	Distance from the heat pump in m																			
	1	2	3	4	5	6	7	8	9	10	11	12	13	14	15	16	17	18	19	20
Directivity factor	Sound pressure level at max. heating output in dB(A)																			
Q																				
2	62	56	52,5	50	48	46,4	45,1	43,9	42,9	42	41,2	40,4	39,7	39,1	38,5	37,9	37,4	36,9	36,4	36
4	65	59	55,5	53	51	49,4	48,1	46,9	45,9	45	44,2	43,4	42,7	42,1	41,5	40,9	40,4	39,9	39,4	39
8	68	62	58,5	56	54	52,4	51,1	49,9	48,9	48	47,2	46,4	45,7	45,1	44,5	43,9	43,4	42,9	42,4	42



The directivity factor Q for the different installation variants:

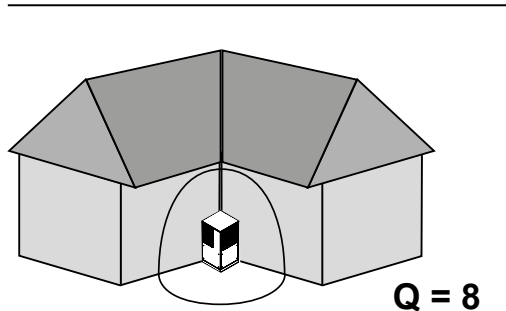
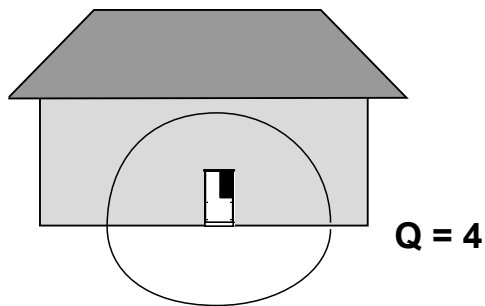
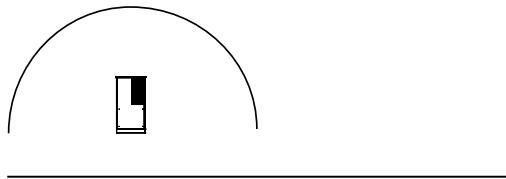
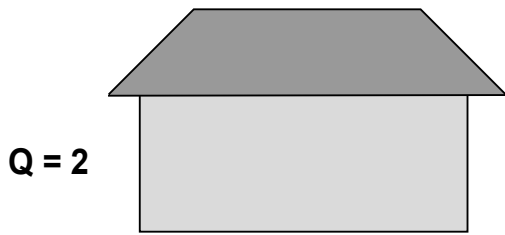

In case of 2 or more units of the same heat pump type, the respective level increase must be added to the corresponding sound pressure level from the following table

Number of n equally loud sound sources	Level increase ΔL in dB
1	0,0
2	3,0
3	4,8
4	6,0
5	7,0
6	7,8
7	8,5
8	9,0
9	9,5
10	10,0
12	10,8

In case of different, not equally loud units, the level increase is read off the following diagram:

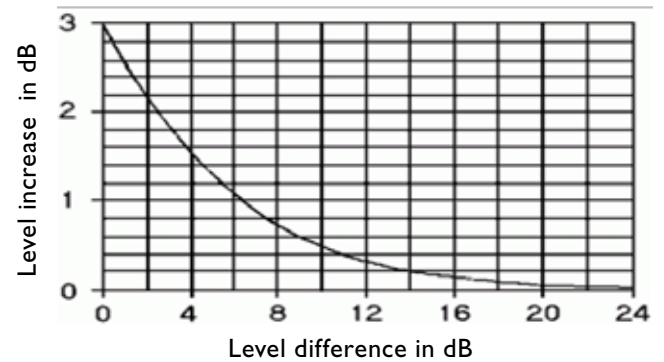

Example: If the level difference between two unequal sound sources is 5 dB, the level increase is an additional 1.2 dB.



INSTALLATION

Place the unit on a solid, level foundation that is capable of bearing weight. Make sure that the foundation is designed for the weight of the heat pump. Materials that meet this requirement can be used for the foundation (concrete, stone slabs, etc.). The ground surface in the air outlet area of the heat pump must be permeable to water.



CAUTION

In the air outlet area the air temperature is ca. 5 K below the ambient temperature. Under certain climatic conditions, therefore, an ice layer can form in the air outlet area. Install the heat pump so that the air blower does not blow in the direction of footpaths.



NOTICE

Always observe the installation plan for the respective unit model. Note the size and minimum clearances.



Installation plan for respective unit model.



NOTICE

Set up the unit so that the switch cabinet side (= operating side) is accessible at all times.

PREPARING FOR INSTALLATION

LW 71... / LW 81...:

- ① Remove facing panels on the switch cabinet side (= operator side) and the water connection side of the unit...

Loosen quick-release screws. Turn counter-clockwise 90°...

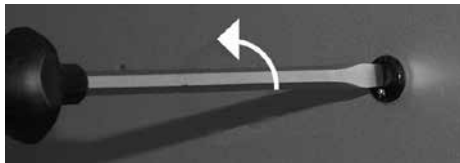

- ② On both sides, pull facing panel outward, detach at top and set securely aside.



LW 101... THROUGH LW 180...:

- ① Remove lower facing panels on the switch cabinet side (= operator side) and the water connection side of the unit...

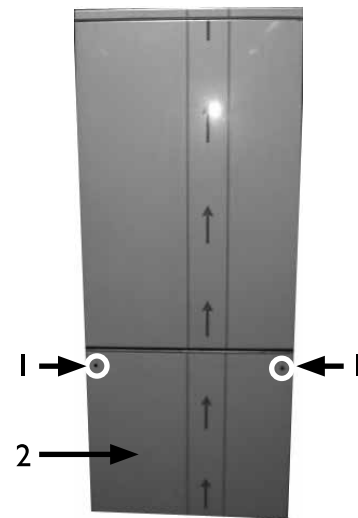

- 1 Quick-release screws
- 2 Lower facing panel

Loosen quick-release screws. Turn counter-clockwise 90°...

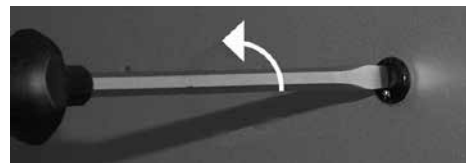



- ② On both sides, pull lower facing panel upward and outward, detach and set securely aside.



LIFTING THE UNIT WITH PIPES (only LW 71... through LW 180...)

The units LW 71... through LW 180... can be lifted with 3/4" pipes (provided by customer) that are suitable for the weight of the respective unit. Special holes are provided in the frame for this purpose.



NOTICE

For mode LW 251... and higher, lifting with pipes is not possible.

- ① Insert the pipes through the holes in the frame on the switch cabinet side (= operator side)...

LW 71... / LW 81...:



LW 101... through LW 180...:



Make sure that pipes do not damage cable assemblies and components in the unit...

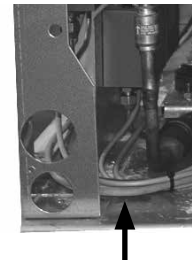

Guide pipes carefully past cable assemblies and components in the unit...

- ② Guide pipes out through the holes on the water connection side...

LW 71... / LW 81...:



LW 101... through LW 180...:





- ③ Lift unit by the pipes, with at least four persons, and place on the base. Make sure that the frame of the unit is in full contact with the underlying surface.

LIFTING THE UNIT WITH A CRANE

NOTICE
Models LW 251... and higher must be lifted using a crane.

- ① Remove side laths on the wooden pallet...

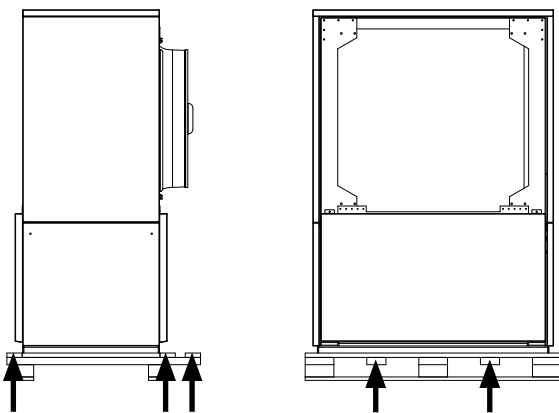

- ② Guide lifting straps under the unit. Insert laths or beams between the lifting straps and the unit in order to prevent damage to the housing, or remove facing panels (see removal instructions under "Attaching air flow baffles")...

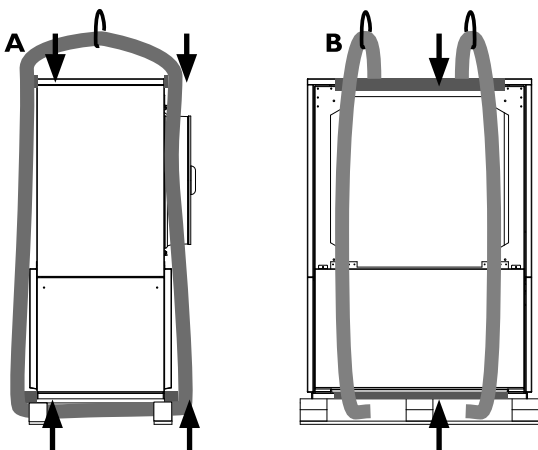

A Front view (operator side)
B Side view I



DANGER
Lifting straps should not be too close together or too near the center; otherwise the unit may tip!

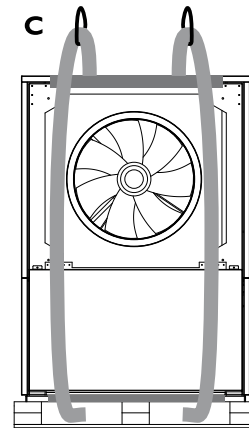

C Side view 2



ATTENTION
Guide lifting straps past the fan on the side. Make sure the straps do not press against the ventilator during transport.

- ③ Lift unit with the crane and place on the base. Make sure that the frame of the unit is in full contact with base.

ATTACHING THE AIR FLOW BAFFLES
(only for LW 101... through LW 310...)



WARNING
Unit has rotating parts.
For safety reasons, mount the two air flow baffles on the unit before continuing with any other work.

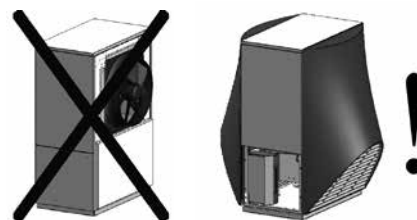



① If you have not already done so, remove lower facing panels on the switch cabinet and water connection side of the unit...

①.①

To do so, loosen the two quick-release screws on the lower facing panels...

①.②

Pull each facing panel forward, detach from the unit and set securely aside...

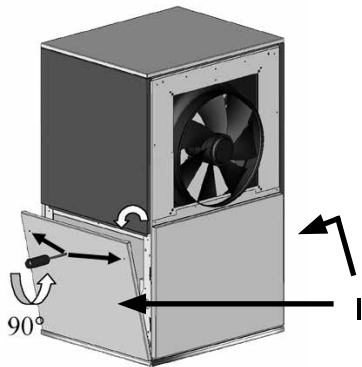

1 lower facing panels

② Remove upper facing panels from unit...

②.①

To do so, loosen the two screws on the lower edges of the upper facing panels...

②.②

Pull each facing panel downward and forward, detach from top cover of unit and set securely aside...

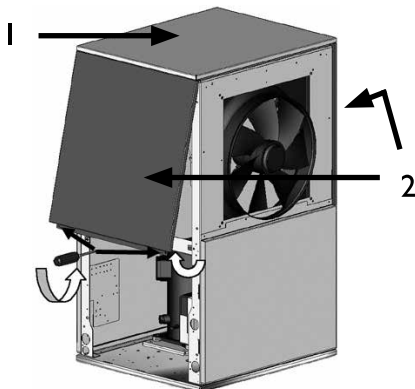

1 top cover of unit
2 upper facing panels

③ The top cover of the unit was fastened by the upper facing panels. After removal of the upper facing panels, the top cover is loose. Remove top cover and set securely aside...

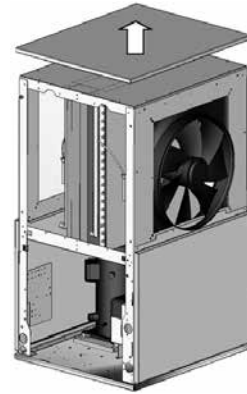

④ Install air flow baffles...



ATTENTION

Remove the protective sheeting from the air flow baffles before installation

④.①

Suspend air flow baffles on the brass bushings on the top side of the frame...

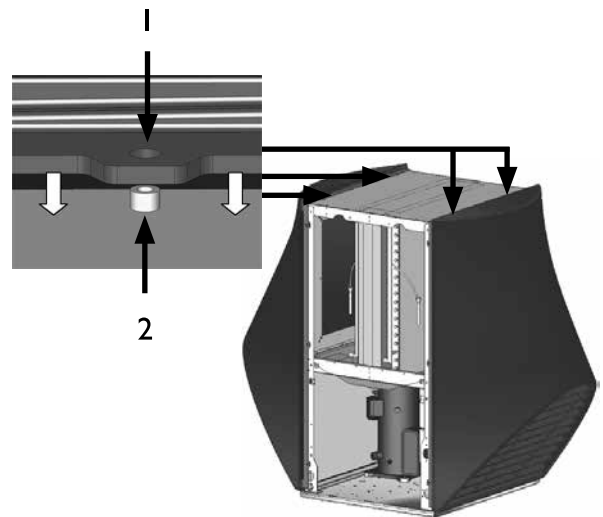

1 eyelet on air flow baffle
2 brass bushing on frame



④•②

Bolt air flow baffles to the frame on the switch cabinet side (= operator side) and water connection side...

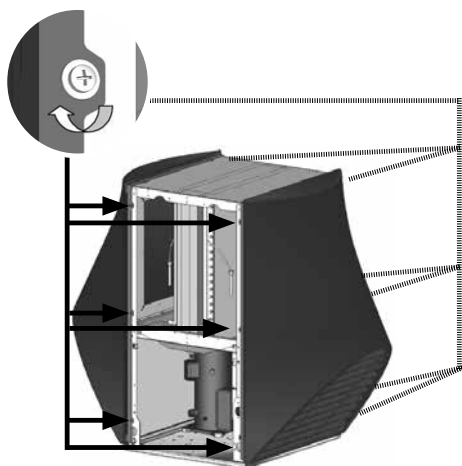

⑤ Return top cover to frame...

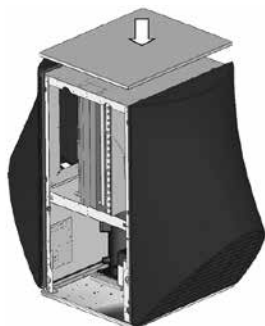

⑥ Suspend upper facing panels in the top cover. Bolt to the frame at bottom...

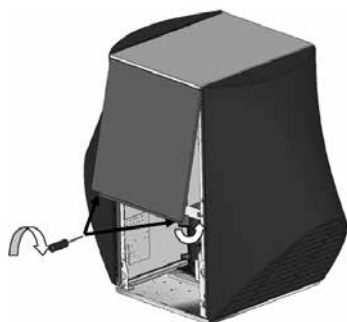

The air flow baffles are now installed. You can now carry out mounting and installation work on the unit, and afterwards attach the lower facing panels. (see “Electrical connection work”, “Heat pump side connection of control and sensor wires”) ⑥.

INSTALLATION / CONNECTION TO HEATING CIRCUIT

! ATTENTION

Connect the unit to the heating circuit according to the hydraulic diagram for the respective model.



“Hydraulic connection” instructions.



NOTICE

Check to make sure that the diameters and lengths of the pipes for the heating circuit (including the ground lead between the heat pump and the building!) are sufficiently dimensioned.



NOTICE

Circulating pumps must be multi-stage. They must be able to deliver at least the minimum hot water flow rate required for your model.



Overview “Technical data/scope of delivery”, “Heating circuit” section.



ATTENTION

The hydraulic system must be equipped with a buffer tank, the required volume of which depends on the model of your unit.



ATTENTION

When installing the connections, always secure the connections on the unit from twisting, in order to prevent damage to the copper pipes in the interior of the unit.



- ① Rinse heating circuit thoroughly prior to connecting the unit to the heating circuit...



NOTICE

Contamination and deposits in the heating circuit can cause malfunctions.

- ② Install shut-off devices for the hot water outflow (forward flow) and hot water inflow (return flow) on the heat pump side...



NOTICE

During installation of the shut-off devices, the liquefier of the heat pump can be rinsed, if necessary.



CAUTION

The condenser may be rinsed only by customer service personnel authorized by the manufacturer.

- ③ Connect the unit to the pipes of the heating circuit via vibration decouplers. They must be installed in order to prevent damage from vibrations to the pipes.



NOTICE

Vibration decouplers are available as accessories.

LW 71... / LW 81...:



- 1 Hot water inflow (return flow) connection
- 2 Hot water outflow (forward flow) connection
- 3 Condensate water hose

LW 101... / LW 121...

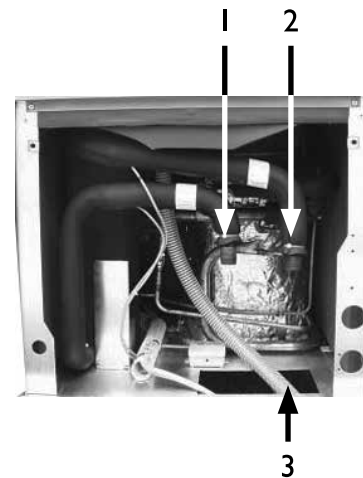

- 1 Hot water inflow (return flow) connection
- 2 Hot water outflow (forward flow) connection
- 3 Condensate water hose

LW 140... THROUGH LW 310...

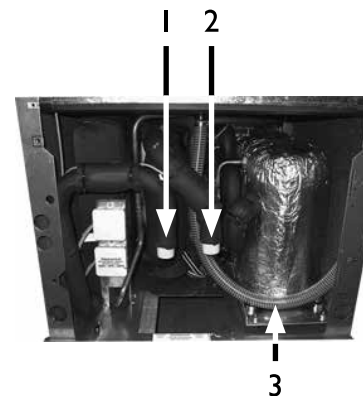

- 1 Hot water inflow (return flow) connection
- 2 Hot water outflow (forward flow) connection
- 3 Condensate water hose

- ④ Install the condensate water hose in the unit so that there is no contact with refrigerant pipes...
- ⑤ Make sure that frost-free condensate discharge is ensured...



Installation plan for respective unit model.

- ⑥ Seal empty pipes on unit side.



CONDENSATE DISCHARGE

The condensate from the air must be discharged frost-free via a condensate pipe with a minimum diameter of 50 mm. For underlying surfaces that are permeable to water, it is sufficient to insert the condensate pipe vertically at least 90 cm into the ground. If the condensate is discharged into drainage or sewage systems, install frost-free with gradient.

Discharge of the condensate into the sewage system is permitted only via a funnel siphon, which must be accessible at all times.

Pressure relief

Equip the heating circuit in accordance with local standards and directives with a safety valve and an expansion tank.

Also install filling and emptying devices, shut-off devices and non-return valves in the heating circuit.

Overflow valve

Use an overflow valve for tanks integrated in series to ensure the minimum flow rate of the heating circuit volume flow through the heat pump. The overflow valve must be dimensioned so that the minimum flow rate of the volume flow through the heat pump is ensured when the heating circuit is shut off.

 “Set the overflow valve”, page 25

Buffer tank

The hydraulic connection of the heat pump requires a buffer tank in the heating circuit. The required volume of the buffer tank is calculated based on the following formula:

$$V_{\text{buffer tank}} = \frac{\text{Minimum flow rate of heat circuit volume flow / hour}}{10}$$

 For the minimum flow rate of the heat circuit volume flow, see overview “Technical data/Scope of delivery”, “Heating circuit” section.

In mono-energetic air/water systems, integrate the buffer tank in the heating water outflow (forward flow) before the overflow valve.

Circulating pumps

! **CAUTION**
Always note the model.

Do not use regulated circulating pumps.

Circulating pumps and domestic hot water circulation pumps must be multi-stage pumps.

Water heating

Water heating with the heat pump requires an additional hot water circuit, parallel to the heating circuit. Make sure that the heating water charge is not channeled through the buffer tank of the heating circuit.

 “Hydraulic connection” instructions.



Hot-water tank

If the heat pump will be used for heating hot water, you must integrate special hot-water tanks in the heat pump system. The storage volume must be sufficient so that the required hot water quantity is available even during a power outage.



NOTICE

The heat exchanger surface of the hot water tank must be dimensioned so that the heating capacity of the heat pump is transferred with minimal spreading.

We offer a variety of hot-water tanks for you to choose from. They are optimized for use with your heat pump.



NOTICE

Integrate the hot-water tank in the heat pump system corresponding to the hydraulic diagram for your system.

Electrical connections

Observe the following when performing all work:



DANGER

Danger of fatal injury due to electric current!

Electrical connections may be installed only by qualified electricians.

Before opening the unit, disconnect the system from the power supply and secure it from being switched back on!



WARNING

Observe the relevant EN, VDE and/or applicable local safety regulations during the installation and during all electrical work.

Comply with technical connection requirements of the responsible power supply company (if required by the latter)!

POWER CONNECTION

It is not necessary to open the electric switch cabinet in order to connect the power to the heat pump. The power is connected at the connection boxes on the water connection side.

① If the unit is closed, open facing panels...



“Preparing for installation”

② Open connection boxes...

LW 71... / LW 81...:

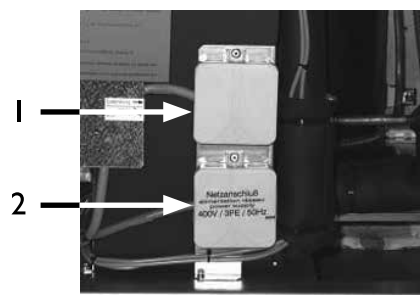

1 Connection box for electric heating element

2 Connection box for compressor



LW 101... / LW 121...

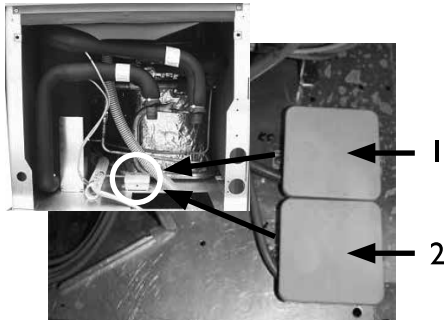

- 1 Connection box for electric heating element
- 2 Connection box for compressor

LW 140... THROUGH LW 310...

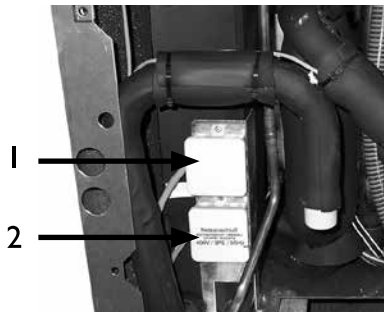

- 1 Connection box for electric heating element
- 2 Connection box for compressor

- ③ Connect power cable to the connection box (Electric heating element with the LW 310A on-site)...
- ④ Close connection box...
- ⑤ Install power cable in a conduit as far as where it enters the building and from there on to the fuse box...
- ⑥ Connect power cable to power supply.

! ATTENTION
Ensure clockwise rotary field of the load power supply (compressor).
– An incorrect rotary field of the compressor during operation can cause serious, irreparable damage to the compressor.

! ATTENTION
The power supply for the heat pump must be equipped with an all-pole miniature circuit-breaker with at least 3 mm contact spacing to IEC 60947-2.
Note the level of the release current.

Overview “Technical data/scope of delivery”, “Electric” section.

! ATTENTION
If using the unit in 3~230V systems, please note that the residual-current circuit breaker (RCCB) used must be AC-DC sensitive.

HEAT PUMP SIDE CONNECTION OF THE CONTROL AND SENSOR WIRES

The heat pump is connected to the heating and heat pump regulator by means of the control and sensor wires. They are connected at the electric switch cabinet on the switch cabinet side (= operator side) of the heat pump.

LW 71... / LW 81...:

- ① Loosen mounting screws of the electric switch cabinet inside the unit...

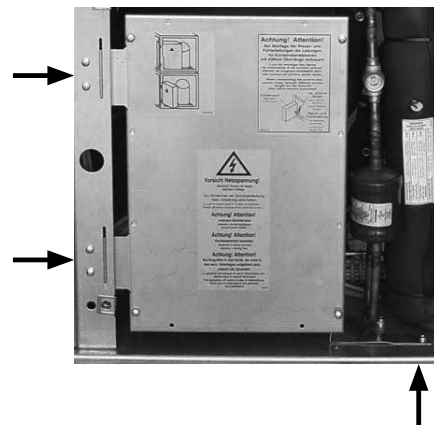

- ② Suspend electric switch cabinet outside in the provided recesses of the frame...

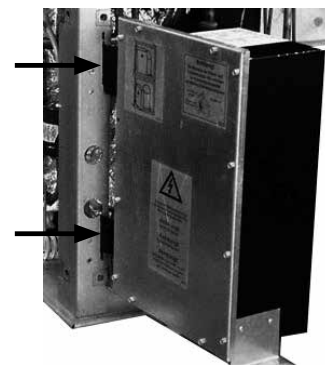

! ATTENTION
Do not tip electric switch cabinet.



- ③ Screw control and sensor wires to the two connectors on the back of the electric switch cabinet...
- ④ After connecting the control and sensor wires, fasten the electric switch cabinet in its original position...
- ⑤ Guide control and sensor wires out of the unit...



NOTICE

In order to enable unhinging of the electric switch cabinet in the event that customer service is necessary, the control and sensor wires in the heat pump must have an excess length of about 15 cm.

- ⑥ Install control and sensor wires in a conduit as far as where they enter the building and from there on to the heating and heat pump regulator...
- ⑦ Connect control and sensor wires to the heating and heat pump regulator according to the terminal diagram and the circuit diagrams for the respective model...



“Terminal diagrams” and “Circuit diagrams” for the respective model.



Operating manual of the heating and heat pump regulator.

- ⑧ Seal empty pipes on unit side...
- ⑨ Screw facing panels onto the heat pump.



NOTICE

Electric heating element is connected for 6 kW (9 kW) at factory. It can be connected for 2(3) or 4 kW (6 kW) on the contactor Q5 (Q6).



For further information, see the adhesive label on the electric heating element.

LW 101... THROUGH LW 310...

- ① Screw control and sensor wires to the two connectors on the side of the electric switch cabinet...



- ② Guide control and sensor wires inside the unit through the provided cable duct to the water connection side...

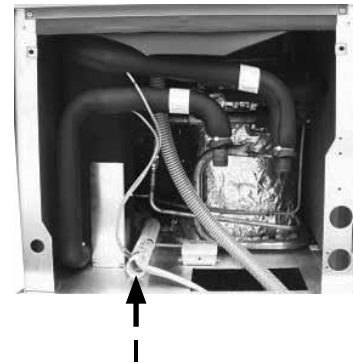

1 Cable duct for control and sensor wires

- ③ Guide control and sensor wires out of the unit...



NOTICE

In order to enable unhinging of the electric switch cabinet in the event that customer service is necessary, the control and sensor wires in the heat pump must have an excess length of about 15 cm.

- ④ Install control and sensor wires in a conduit as far as where they enter the building and from there on to the heating and heat pump regulator...
- ⑤ Connect control and sensor wires to the heating and heat pump regulator according to the terminal connection diagram and the circuit diagrams for the respective model...



“Terminal diagrams” and “Circuit diagrams” for the respective model.



Operating manual of the heating and heat pump regulator.



- ⑥ Seal empty pipes on unit side...
- ⑦ Screw facing panels onto the heat pump...

Place lower facing panels diagonally into the frame, close at top and fasten with in quick-release screws...

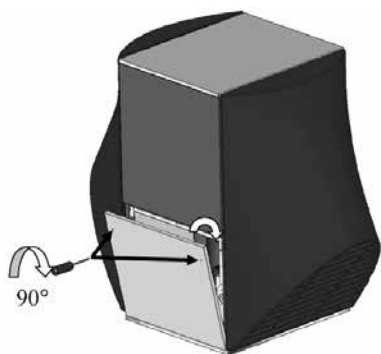

The unit is now closed.

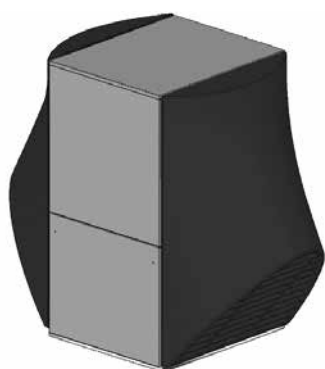

Rinsing, filling and bleeding the system

! ATTENTION

The system must be absolutely free from air before commissioning.

WATER QUALITY OF THE FILL AND ADDITIONAL WATER IN HOT WATER HEATING SYSTEMS

ACCORDING TO VDI 2035 PART I AND II

Use of modern, energy-efficient heat pump systems is becoming increasingly widespread. Their ingenious technology enables these systems to achieve very good efficiencies. The decreasing space available for heat generators has led to the development of compact units with increasingly smaller cross-sections and high capacities. This means the complexity of the systems and the material diversity are also increasing, which plays an important role especially in their corrosion behaviour. The heating water not only affects the efficiency of the system, but also the life of the heat generator and the heating components of a system.

The guide values of VDI 2035 Part I and Part II must therefore be complied with as minimum requirements for proper operation of the systems. Our practical experience has shown that the safest and most trouble-free running of the systems is achieved with so-called low-salt operation.

VDI 2035 Part I gives important information and recommendations regarding scaling and its prevention in heating and domestic hot water heating systems.

VDI 2035 Part II primarily deals with the requirements for reducing heating water corrosion in hot water heating systems.

PRINCIPLES OF PART I AND PART II

The occurrence of scaling and corrosion damage in hot water heating systems is low, if

- proper planning and commissioning is carried out
- the system is closed in corrosion terms
- adequately dimensioned pressurising is integrated
- the guide values for the heating water are complied with
- and regular servicing and maintenance are carried out.

A system log should be kept, in which the relevant planning data is entered (VDI 2035).



DAMAGE THAT CAN OCCUR IN CASE OF NON-COMPLIANCE

- Malfunctions and the failure of components (e.g. pumps, valves)
- Internal and external leaks (e.g. from heat exchangers)
- Cross-section reduction and blockaging of components (e.g. heat exchanger, pipes, pumps)
- Material fatigue
- Gas bubbles and gas cushion formation (cavitation)
- Negative effect on heat transfer (formation of coatings, deposits) and associated noises (e.g. boiling noises, flow noises)

LIMESCALE – THE ENERGY KILLER

Filling with untreated drinking water inevitably leads to the precipitation of all calcium as scale. The consequence: limescale deposits form on the heat transfer surfaces of the heating. The efficiency falls and the energy costs rise. A rule of thumb is that 1 millimetre of limescale deposit causes an energy loss of 10%. In extreme cases it can even cause damage to the heat exchangers.

WATER SOFTENING TO VDI 2035 – PART I

If the water is softened before the heating is filled, in accordance with the VDI 2035 guidelines, no scale can form. This effectively and permanently prevents limescale deposits and the resulting negative effects on the entire heating system.

CORROSION – AN UNDERESTIMATED PROBLEM

VDI 2035, Part II, deals with the problem of corrosion. Softening the heating water can prove to be insufficient. The pH value can significantly exceed the limit of 10. pH values higher than 11 can set in, which even damage rubber seals. The VDI 2035, Part I guidelines are fulfilled, however, VDI 2035, Part 2 suggests a pH value between 8.2 and maximum 10.

If aluminium materials are used, which is the case in many modern heating systems, a pH value of 8.5 must not be exceeded, because otherwise there is a threat of corrosion – and aluminium is attacked without the presence of oxygen. Therefore, apart from softening the heating fill and additional water, the heating water should also be appropriately conditioned. This is the only way to comply with the VDI 2035 requirements and the recommendations and installation instructions of the heat pump manufacturer.

Part 2 of VDI 2035 also points out the reduction in total salt content (conductivity). The risk of corrosion is far lower if deionised water is used than is the case if the system is operated with salty, i.e. softened water.

Even if the water has been softened beforehand, it contains dissolved, corrosion-promoting salts, which act as electrolytes due to the use of different materials in the heating system and therefore accelerate corrosion processes. This can ultimately result in pitting.

Contamination and deposits in the heating circuit can cause malfunctions

RINSE, FILL AND BLEED THE HEATING CIRCUIT AND HOT WATER BUFFER TANK

To bleed the hot water tank, the heating circuit and hot water circuit must be rinsed simultaneously.

ON THE SAFE SIDE WITH LOW-SALT OPERATION

The problems listed above do not occur at all with low-salt operation, as neither corrosive salts such as sulphates, chlorides and nitrates nor alkalis sodium hydrogen carbonate are in the heating water. The corrosive properties of deionised water are very low and in addition, fur cannot form in the boiler. This is the ideal approach for closed heating circuits, in particular, because low oxygen input into the heating circuit can also be tolerated.

In general, when the system is filled with deionised water, the pH value sets itself within the ideal range due to “self-alkalinisation”. If necessary, a pH value of 8.2 can be very easily alkalisied by adding chemicals. In this way, optimum protection of the entire heating system is achieved.

MONITORING

Analytical recording and monitoring of the relevant water values and the added active conditioning substances is of decisive importance. Therefore, they should be monitored regularly using appropriate water test equipment.



Insulating the hydraulic connections

Insulate the vibration decouplers and the outside pipes of the heating circuit so that they are sealed against vapor diffusion.



NOTICE

Insulate in accordance with applicable local standards and directives.



ATTENTION

Install the outside pipes of the heating circuit beneath the frost line.

- ① Check seals of all hydraulic connections. Conduct pressure test...
- ② Insulate all connections and lines of the heat circuit and the heat source.

Set the overflow valve



REMARQUE

The activities in this section are only necessary for in-line tank integration.

Complete the worksteps quickly, otherwise the maximum return temperature can be exceeded and the heat pump switches to high-pressure fault.

Turn the adjusting knob at the overflow valve to the right to increase the temperature difference (the temperature drop), turn it to the left to reduce it.

System is running in heating mode (ideally in cold condition).

- ① In case of low heating curve: Set the system to "Forced heating"...



Operating manual of the heating and heat pump controller.

- ② Shut off valves to the heating circuit...

- ③ Ensure that the total flow is routed via the overflow valve...

- ④ Read out the flow and return temperature at the heating and heat pump controller...



Operating manual of the heating and heat pump controller.

- ⑤ Turn the adjusting knob (1) of the overflow valve (2) until the temperature drop between the flow and return temperature is set as follows:

External temperature	Recommended settings
-10 °C	4 K
0 °C	5 K
10 °C	8 K
20 °C	9 K
30 °C	10 K

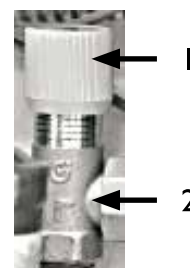

- ⑥ Open valves to heating circuit...
- ⑦ Reset the heating and heat pump controller.



Commissioning



WARNING!

Prior to commissioning the unit, the air flow baffles must be mounted and the facing panels closed.



NOTE.

The commissioning has to be in the heating mode.

- ① Carry out a thorough installation check and work through the general checklist...



Manufacturer's homepage.

By checking the installation you prevent damage to the heat pump system, which could be caused by work carried out improperly.

Check that...

- **clockwise rotary field** of the load power supply (compressor) is ensured.
- The heat pump **installation and assembly** have been carried out according to the requirements of this operating manual.
- the electrical installation work has been completed properly.
- The power supply for the heat pump must be equipped with an all-pole automatic circuit-breaker with at least 3 mm contact spacing to IEC 60947-2.
- The heating circuit is flushed, filled and thoroughly vented.
- All valves and shut-off devices of the heating circuit are open.
- All pipe systems and components of the system are leaktight.

- ② Carefully fill out and sign the completion report for heat pump systems...



Manufacturer's homepage.

- ③ Within Germany and Austria:
Send completion report for heat pump systems and general checklist to the manufacturer's factory customer service department...

In other countries:

Send completion report for heat pump systems and general checklist to the manufacturer's local partner...

- ④ The heat pump system is commissioned by customer service personnel authorised by the manufacturer. There is a fee for starting up!

SAFETY TEMPERATURE LIMITER

A safety temperature limiter is built into the electric heating element (depending on model). In the event of a malfunction in the heat pump or air in the system, check whether the reset button of the safety temperature limiter has tripped. If this is the case, push in the button.

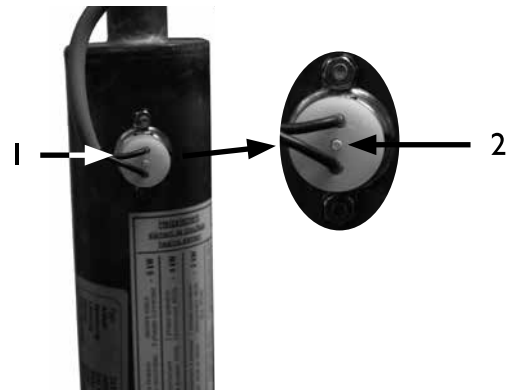

- 1 Safety temperature button on electric heating element
- 2 Reset button



Dismantling



DANGER

Danger of fatal injury due to electric current!

Electrical connections may be installed only by qualified electricians.

Before opening the unit, disconnect the system from the power supply and secure it from being switched back on!



WARNING

Only qualified heating or cooling system technicians are allowed to remove the unit from the system.



ATTENTION

Recycle or provide for proper disposal of unit components, refrigerants and oil in accordance with the applicable regulations, standards and directives.

REMOVAL OF THE BUFFER BATTERY



ATTENTION

Before scrapping the heating and heat pump regulator, remove the buffer battery on the processor board. The battery can be pushed out using a screwdriver. Dispose of battery and electronic components in keeping with environmental considerations.



Technical data / scope of delivery

Heat pump type	Brine/water Air/water Water/water	• applicable — not applicable
Installation location	Indoors Outdoors	• applicable — not applicable
Conformity		CE
Performance data	Heating capacity/COP at	
	A7/W35 Standard point acc. to EN14511	2 Compressors 1 Compressor
	A7/W45 Standard point acc. to EN14511	2 Compressors 1 Compressor
	A2/W35 Operating point according to EN14511	2 Compressors 1 Compressor
	A10/W35 Operating point according to EN14511	2 Compressors 1 Compressor
	A-7/W35 Operating point according to EN14511	2 Compressors 1 Compressor
	A-15/W65	2 Compressors 1 Compressor
		kW ... kW ... kW ... kW ... kW ... kW ... kW ...
Limits of application	Heating circuit	°C
	Heat source	°C
	Additional operating points	°C
Sound	Internal sound pressure level (open air test field, distance of 1m around the engine, average)	dB(A)
	External sound pressure level (open air test field, distance of 1m around the air supplies, average)	dB(A)
	Sound power inside	dB(A)
	Sound power outside	dB(A)
Heat source	Air volume flow at maximum external compression	m³/h
	Maximum external pressure	Pa
Heating circuit	Volume flow: minimum flow rate nominal flow rate A7/W35 EN14511 maximum flow rate	l/h
	Pressure loss heat pump Δp volume flow	bar l/h
	Free compression heat pump Δp volume flow	bar l/h
	Content of buffer tank	l
	3-way valve, heating/hot water	...
General unit data	Dimensions (see dimensional drawing for the specified unit size)	unit size
	Total weight	kg
	Connections Heating circuit	...
	Heat source	...
	Refrigerant Refrigerant type Quantity	... kg
	Free cross section, air channels	mm
	Cross section, condensate water / length from unit	mm m
Electric	Voltage code all-pole circuit breaker heat pump **)	... A
	Voltage code circuit breaker control voltage **)	... A
	Voltage code circuit breaker electric heating element **)	A
Heat Pump	Effective power consumption in standard point A7/W35 according to EN14511: Power consumption current consumption cosφ	kW A ...
	Maximum device current within the limits of application	A
	Starting current: direct with soft starter	A A
	Protection type	IP
	Output electric heating element 3 2 1 phase	kW kW kW
Components	Circulating pump heating circuit at nominal flow rate: Power consumption current consumption	kW A
Safety equipment	Safety component heating circuit Safety component heat source	Includ. in sc. of del.: • yes — no
Heating and heat pump regulator		Includ. in scope of delivery: • yes — no
Control and sensor wire		Includ. in scope of delivery: • yes — no
Power cable to unit		Includ. in scope of delivery: • yes — no
Electronic soft starter		integrated: • yes — no
Expansion vessels	Heat source: Scope of delivery Volume Initial pressure	• yes — no bar
Overflow valve		integrated: • yes — no
Vibration decouplers	Heating circuit heat source	Included in scope of delivery: • yes — no

UK813517

*) depending on components tolerances and flow **) comply with local regulations n.n. = not detectable w.w. = to choice
1) hot water return 2) hot water flow



	LW 71A	LW 81A	LW 101A	LW 121A
	— • —	— • —	— • —	— • —
	— •	— •	— •	— •
	•	•	•	•
	—	—	—	—
	8,1 3,9	9,4 3,9	10,3 4,2	12,8 4,2
	—	—	—	—
	7,7 3,0	9,0 3,0	10,1 3,5	12,7 3,5
	—	—	—	—
	7,2 3,5	8,4 3,5	9,5 3,7	11,8 3,7
	—	—	—	—
	8,8 4,3	10,3 4,3	11,1 4,4	12,8 4,4
	—	—	—	—
	5,7 2,8	6,6 2,8	7,5 2,9	9,1 2,9
	—	—	—	—
	—	—	—	—
	20 – 58 (60)*	20 – 58 (60)*	20 ¹ – 50 ²	20 ¹ – 50 ²
	-20 – 35	-20 – 35	-20 – 35	-20 – 35
	—	—	A> -7 / 60 ²	A> -7 / 60 ²
	—	—	—	—
	50	50	50	53
	—	—	—	—
	58	62	58	61
	3000	3000	4000	4000
	—	—	—	—
	1000 1500 1900	1200 1750 2200	1500 2000 2500	1650 2500 3100
	0,1 1500	0,12 1750	0,09 2000	0,09 2500
	— —	— —	— —	— —
	—	—	—	—
	—	—	—	—
	1	1	2	3
	145	145	260	280
	R1*AG	R1*AG	R1*AG	R1*AG
	—	—	—	—
	R404A 2,4	R404A 2,8	R407C 4,8	R407C 5,8
	—	—	—	—
	30 1	30 1	30 1	30 1
	3~/PE/400V/50Hz C10	3~/PE/400V/50Hz C10	3~/N/PE/400V/50Hz C10	3~/N/PE/400V/50Hz C16
	1~/N/PE/230V/50Hz B10	1~/N/PE/230V/50Hz B10	1~/N/PE/230V/50Hz B10	1~/N/PE/230V/50Hz B10
	3~/N/PE/400V/50Hz B10	3~/N/PE/400V/50Hz B10	3~/N/PE/400V/50Hz B16	3~/N/PE/400V/50Hz B16
	2,1 4,0 0,75	2,4 4,6 0,75	2,6 5,4 0,7	3,1 6,4 0,7
	8,4	8,4	9,2	11,5
	38 22	45 22	51,5 19	64 23
	24	24	24	24
	6 4 2	6 4 2	9 6 3	9 6 3
	— —	— —	— —	— —
	— —	— —	— —	— —
	—	—	—	—
	—	—	—	—
	—	—	—	—
	•	•	•	•
	— — —	— — —	— — —	— — —
	—	—	—	—
	—	—	—	—
	813510d	813511d	813512c	813513c



Technical data / scope of delivery

Heat pump type	Brine/water Air/water Water/water	• applicable — not applicable
Installation location	Indoors Outdoors	• applicable — not applicable
Conformity		CE
Performance data	Heating capacity/COP at	
	A7/W35 Standard point acc. to EN14511	2 Compressors 1 Compressor
	A7/W45 Standard point acc. to EN14511	2 Compressors 1 Compressor
	A2/W35 Operating point according to EN14511	2 Compressors 1 Compressor
	A10/W35 Operating point according to EN14511	2 Compressors 1 Compressor
	A-7/W35 Operating point according to EN14511	2 Compressors 1 Compressor
	A-15/W65	2 Compressors 1 Compressor
		kW ... kW ... kW ... kW ... kW ... kW ... kW ...
Limits of application	Heating circuit	°C
	Heat source	°C
	Additional operating points	°C
Sound	Internal sound pressure level (open air test field, distance of 1m around the engine, average)	dB(A)
	External sound pressure level (open air test field, distance of 1m around the air supplies, average)	dB(A)
	Sound power inside	dB(A)
	Sound power outside	dB(A)
Heat source	Air volume flow at maximum external compression	m³/h
	Maximum external pressure	Pa
Heating circuit	Volume flow: minimum flow rate nominal flow rate A7/W35 EN14511 maximum flow rate	l/h
	Pressure loss heat pump Δp volume flow	bar l/h
	Free compression heat pump Δp volume flow	bar l/h
	Content of buffer tank	l
	3-way valve, heating/hot water	...
General unit data	Dimensions (see dimensional drawing for the specified unit size)	unit size
	Total weight	kg
	Connections Heating circuit	...
	Heat source	...
	Refrigerant Refrigerant type Quantity	... kg
	Free cross section, air channels	mm
	Cross section, condensate water / length from unit	mm m
Electric	Voltage code all-pole circuit breaker heat pump **)	... A
	Voltage code circuit breaker control voltage **)	... A
	Voltage code circuit breaker electric heating element **)	A
Heat Pump	Effective power consumption in standard point A7/W35 according to EN14511: Power consumption current consumption $\cos\phi$	kW A ...
	Maximum device current within the limits of application	A
	Starting current: direct with soft starter	A A
	Protection type	IP
	Output electric heating element 3 2 1 phase	kW kW kW
Components	Circulating pump heating circuit at nominal flow rate: Power consumption current consumption	kW A
Safety equipment	Safety component heating circuit Safety component heat source	Includ. in sc. of del.: • yes — no
Heating and heat pump regulator		Includ. in scope of delivery: • yes — no
Control and sensor wire		Includ. in scope of delivery: • yes — no
Power cable to unit		Includ. in scope of delivery: • yes — no
Electronic soft starter		integrated: • yes — no
Expansion vessels	Heat source: Scope of delivery Volume Initial pressure	• yes — no bar
Overflow valve		integrated: • yes — no
Vibration decouplers	Heating circuit heat source	Included in scope of delivery: • yes — no

UK813517

*) depending on components tolerances and flow **) comply with local regulations n.n. = not detectable w.w. = to choice
 1) hot water return 2) hot water flow



	LW 140A	LW 180A	LW 251A	LW 310A
	— • —	— • —	— • —	— • —
	— •	— •	— •	— •
	•	•	•	•
	—	19,6 3,9	27,3 3,9	35,0 4,0
	14,4 4,3	10,1 4,2	14,1 4,2	19,1 4,2
	—	18,7 3,3	26,1 3,3	34,4 3,5
	13,9 3,5	9,8 3,4	13,7 3,4	18,9 3,6
	—	17,2 3,6	24,0 3,6	31,0 3,5
	13,8 3,7	9,5 3,8	13,2 3,8	16,8 3,6
	—	21,2 4,0	29,2 4,0	37,0 4,1
	14,1 4,4	10,3 4,5	14,2 4,5	20,2 4,3
	—	14,1 2,8	19,4 2,8	25,0 2,8
	10,8 3,0	7,3 2,9	10,1 2,9	13,2 2,9
	—	—	—	—
	—	—	—	—
	20 ¹ – 50 ²	20 ¹ – 50 ²	20 ¹ – 50 ²	20 – 58 (60)*
	-20 – 35	-20 – 35	-20 – 35	-20 – 35
	A> -7 / 60 ²	A> -7 / 60 ²	A> -7 / 60 ²	—
	—	—	—	—
	50	52	57	59
	—	—	—	—
	58	60	65	67
	5600	5600	7800	7800
	—	—	—	—
	2000 2900 3600	2000 3800 4800	2500 5000 6200	4000 6000 10000
	0,12 2900	0,18 3800	0,12 5000	0,04 6000
	— —	— —	— —	— —
	—	—	—	—
	—	—	—	—
	4	4	5	6
	370	420	540	573
	R5/4"AG	R5/4"AG	R5/4"AG	R6/4"AG
	—	—	—	—
	R407C 5,8	R407C 6,8	R407C 9,8	R404A 10,0
	—	—	—	—
	30 1	30 1	30 1	30 1
	3~/N/PE/400V/50Hz C16	3~/N/PE/400V/50Hz C20	3~/N/PE/400V/50Hz C25	3~/PE/400V/50Hz C32
	1~/N/PE/230V/50Hz B10	1~/N/PE/230V/50Hz B10	1~/N/PE/230V/50Hz B10	1~/N/PE/230V/50Hz B10
	3~/N/PE/400V/50Hz B16	3~/N/PE/400V/50Hz B16	3~/N/PE/400V/50Hz B16	— —
	3,4 7,0 0,7	5,0 (2,4) 10,3 (4,9) 0,7 (0,7)	7,0 (3,4) 14,4 (7,0) 0,7 (0,7)	8,71 (4,5) 16,8 (8,7) 0,75 (0,75)
	13,0	18,0	24,5	28
	74 26	51,5 30	74 30	80 38
	24	24	24	24
	9 6 3	9 6 3	9 6 3	— — —
	— —	— —	— —	— —
	— —	— —	— —	— —
	—	—	—	—
	—	—	—	—
	—	—	—	—
	•	•	•	•
	— — —	— — —	— — —	— — —
	—	—	—	—
	—	—	—	—
	813514c	813515d	813516d	813507f



LW 71A

Performance curves

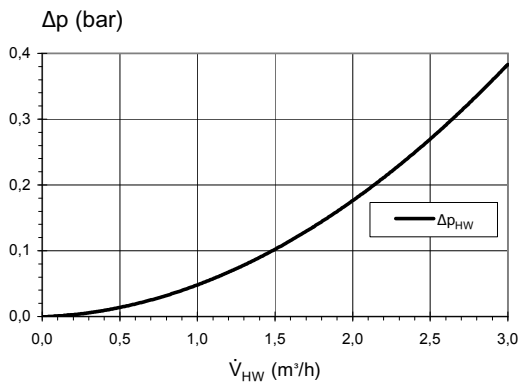
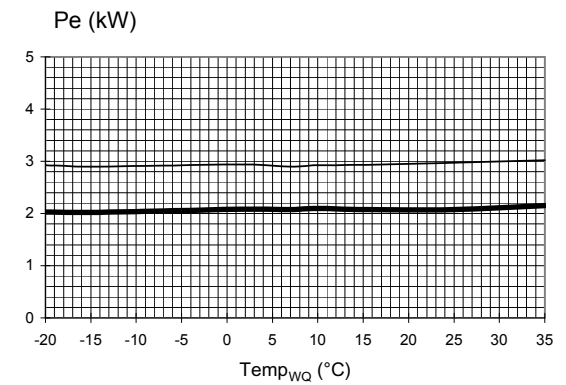
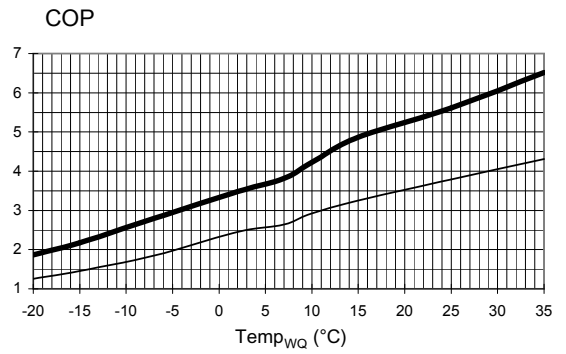
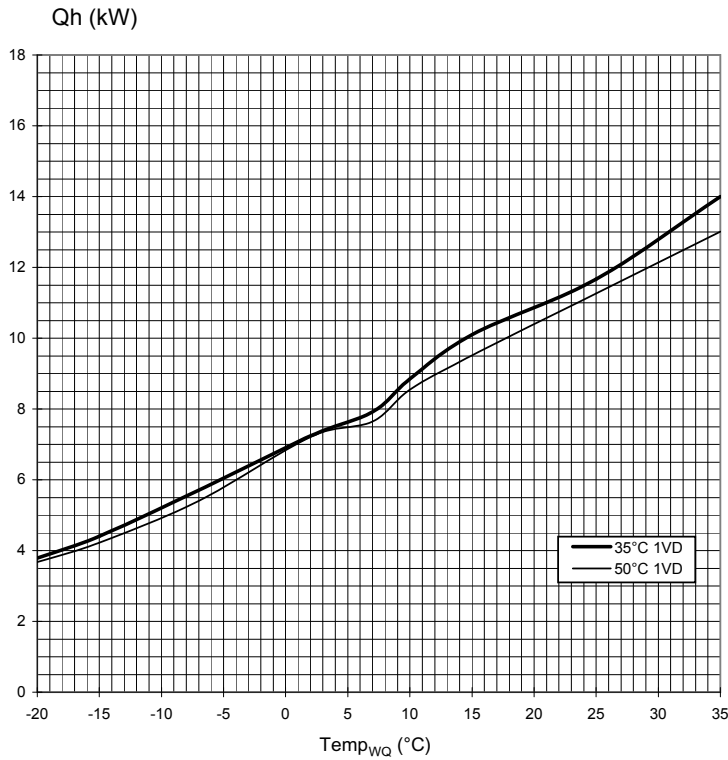

823150

Legend:	UK823129L/170408
V _{HW}	Volume flow, heating water
Temp _{wQ}	Temperature, heat source
Qh	Heating capacity
Pe	Power consumption
COP	Coefficient of performance / efficiency rating
Δp _{HW}	Pressure loss heat pump
VD	Compressor(s)



Performance curves

LW 81A

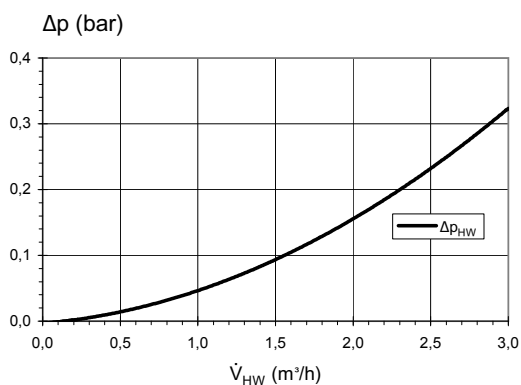
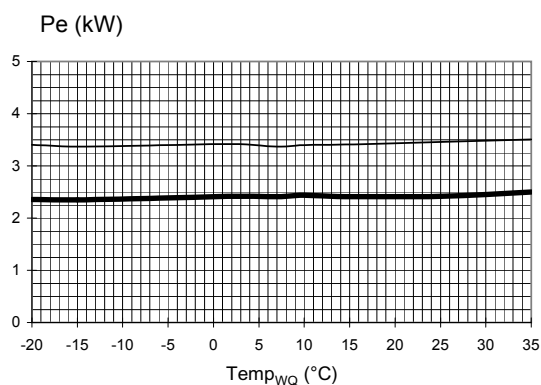
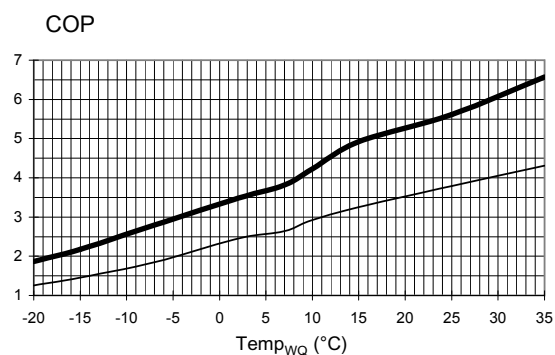
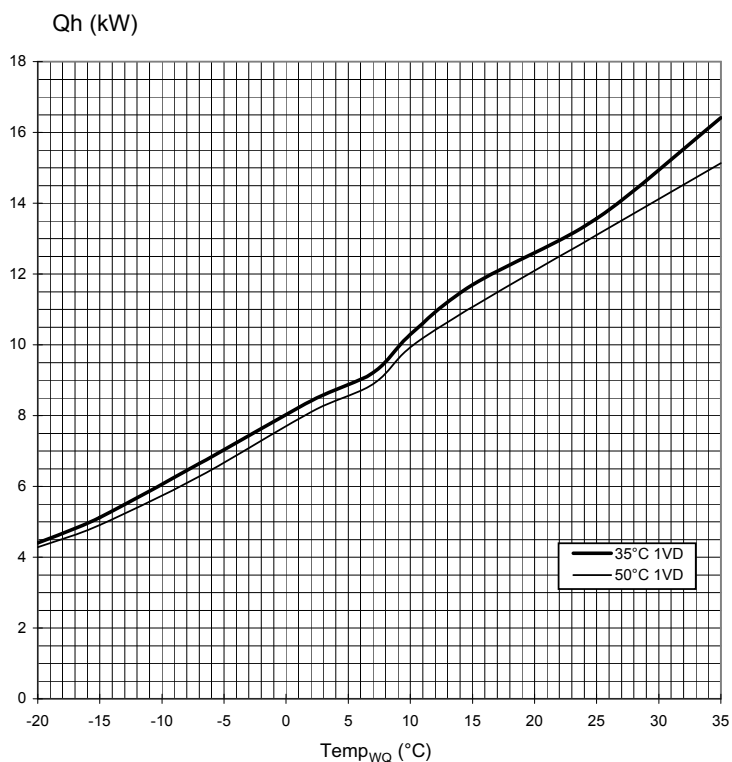

823151

Legend:	UK823129L/170408
V _{HW}	Volume flow, heating water
Temp _{WQ}	Temperature, heat source
Qh	Heating capacity
Pe	Power consumption
COP	Coefficient of performance / efficiency rating
Δp _{HW}	Pressure loss heat pump
VD	Compressor(s)



LW 101A

Performance curves

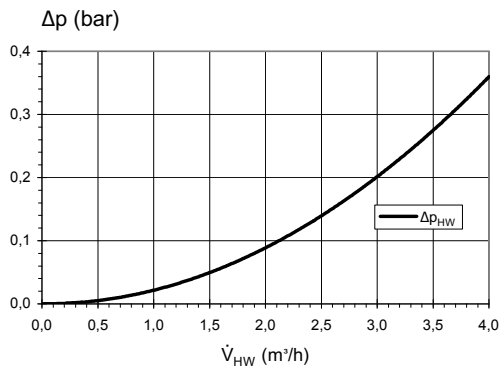
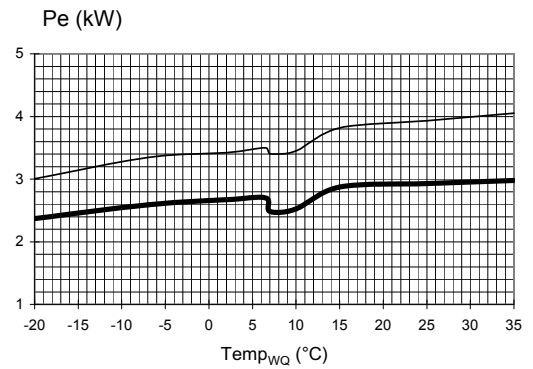
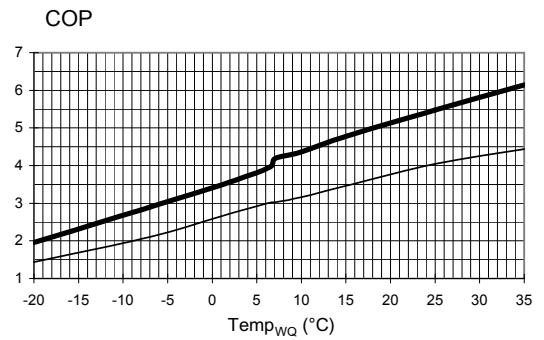
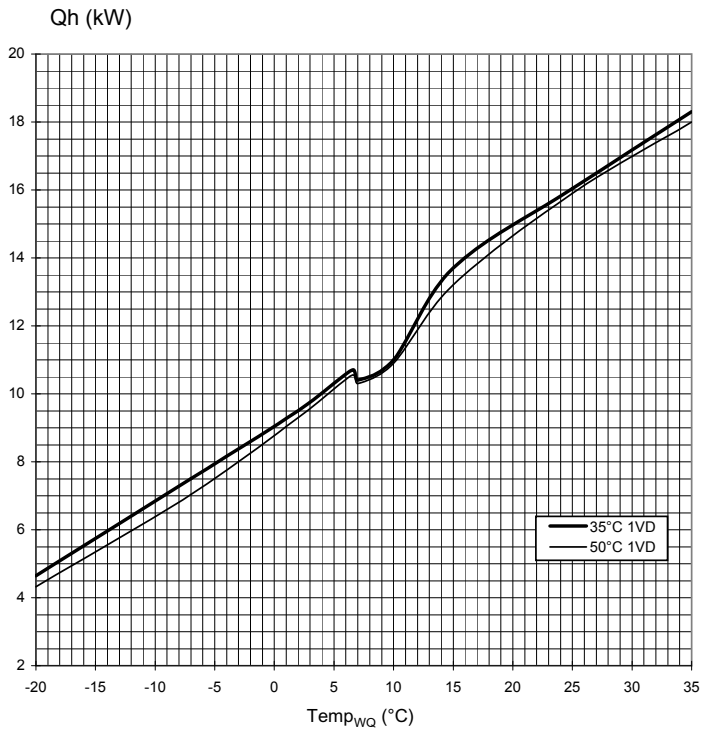

823152

Legend:	UK823129L/170408
\dot{V}_{HW}	Volume flow, heating water
Temp _{wQ}	Temperature, heat source
Qh	Heating capacity
Pe	Power consumption
COP	Coefficient of performance / efficiency rating
Δp _{HW}	Pressure loss heat pump
VD	Compressor(s)



Performance curves

LW 121A

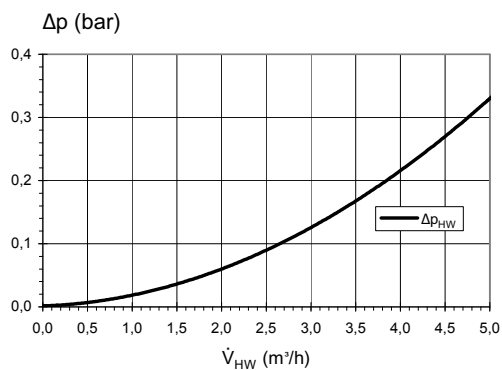
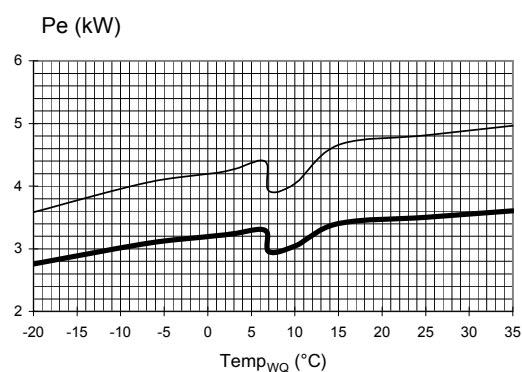
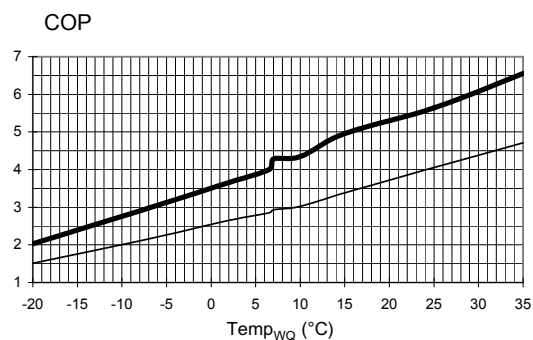
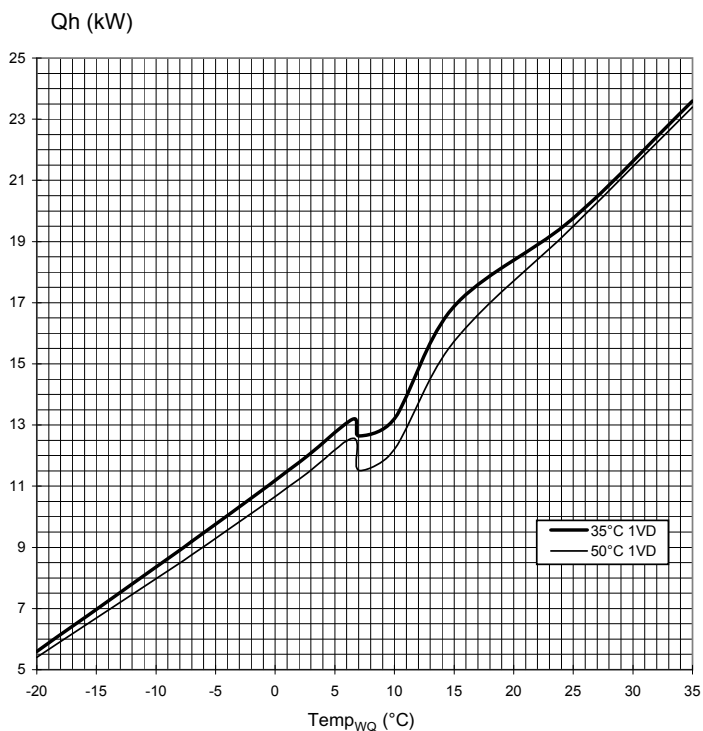

823153

Legend:	UK823129L/170408
\dot{V}_{HW}	Volume flow, heating water
$Temp_{WQ}$	Temperature, heat source
Q_h	Heating capacity
P_e	Power consumption
COP	Coefficient of performance / efficiency rating
Δp_{HW}	Pressure loss heat pump
VD	Compressor(s)



LW 140A

Performance curves

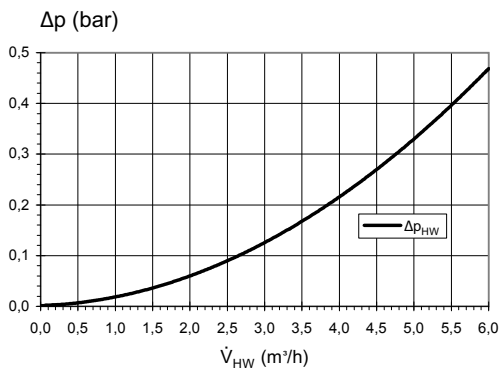
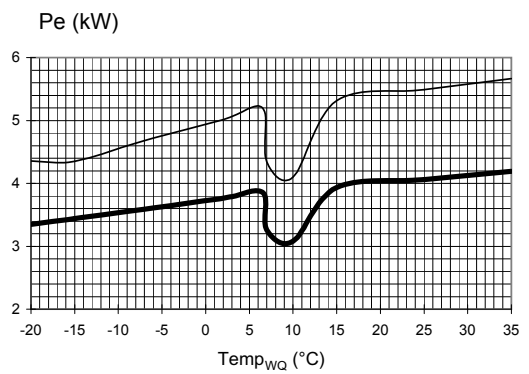
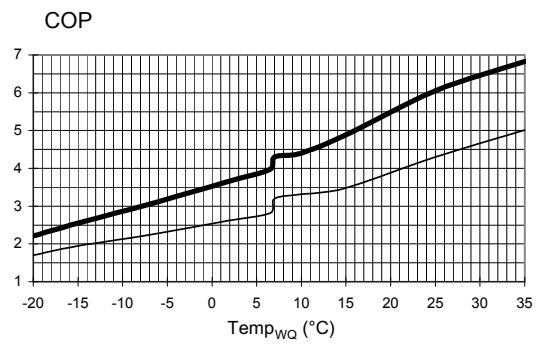
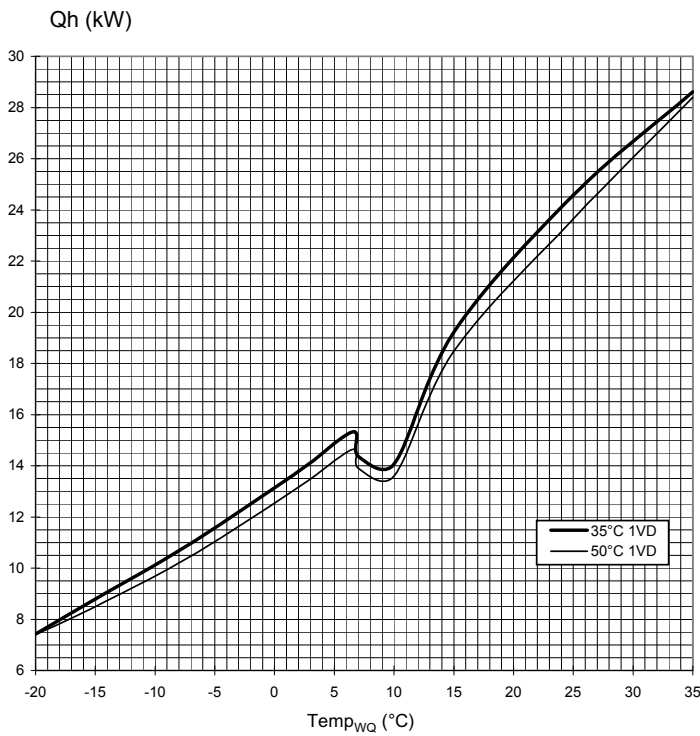

823154

Legend:	UK823129L/170408
\dot{V}_{HW}	Volume flow, heating water
$Temp_{WQ}$	Temperature, heat source
Q_h	Heating capacity
P_e	Power consumption
COP	Coefficient of performance / efficiency rating
Δp_{HW}	Pressure loss heat pump
VD	Compressor(s)



Performance curves

LW 180A

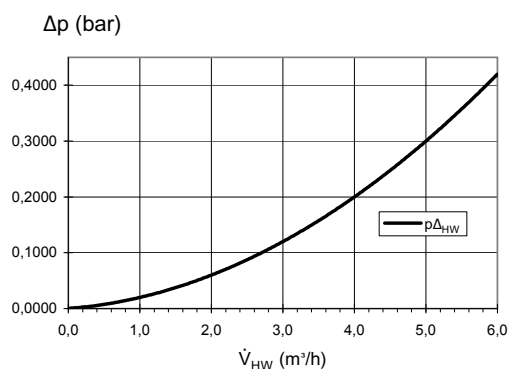
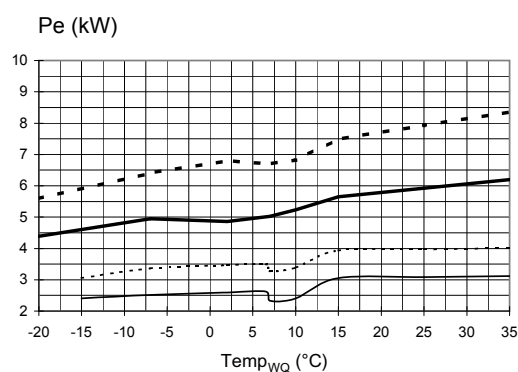
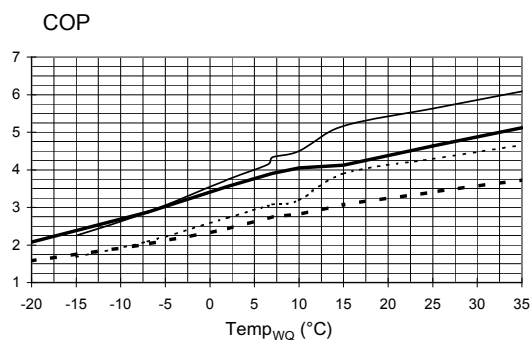
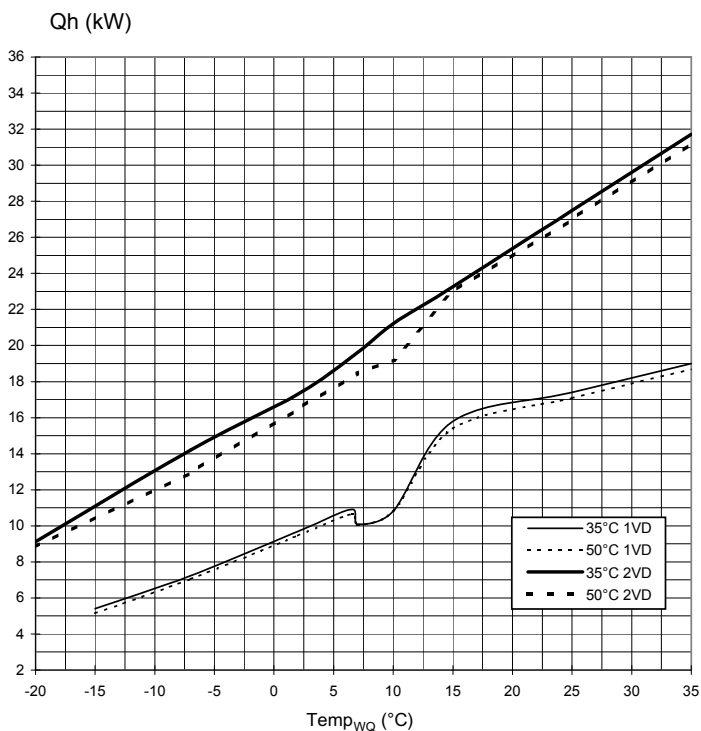

823155

Legend:	UK823129L/170408
\dot{V}_{HW}	Volume flow, heating water
$Temp_{wQ}$	Temperature, heat source
Q_h	Heating capacity
P_e	Power consumption
COP	Coefficient of performance / efficiency rating
Δp_{HW}	Pressure loss heat pump
VD	Compressor(s)



LW 251A

Performance curves

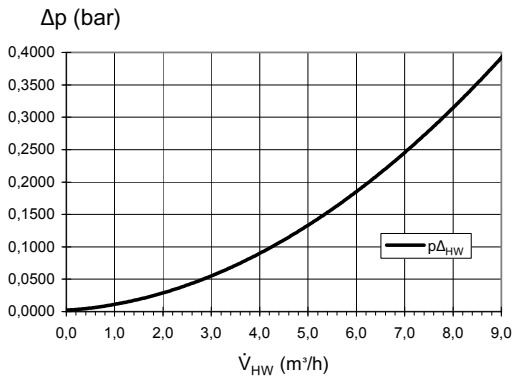
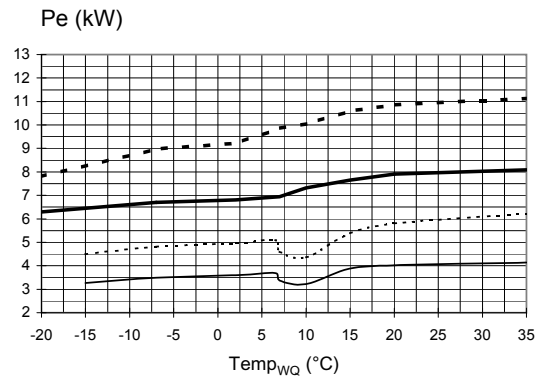
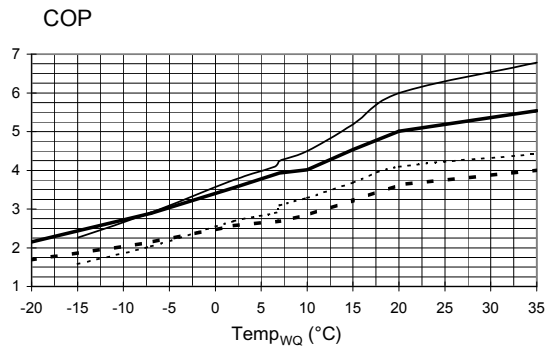
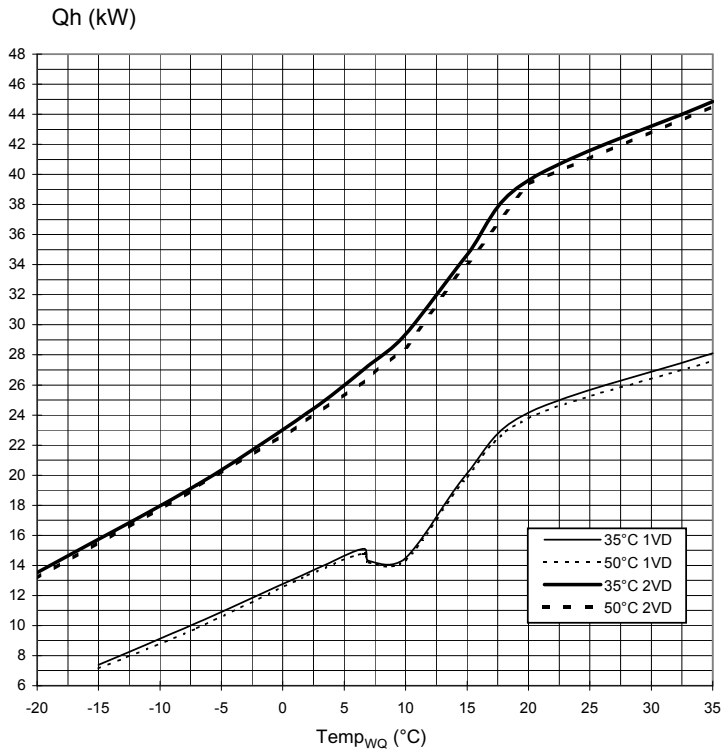

823156a

Legend:	UK823129L/170408
\dot{V}_{HW}	Volume flow, heating water
$Temp_{WQ}$	Temperature, heat source
Q_h	Heating capacity
Pe	Power consumption
COP	Coefficient of performance / efficiency rating
Δp_{HW}	Pressure loss heat pump
VD	Compressor(s)



Performance curves

LW 310A

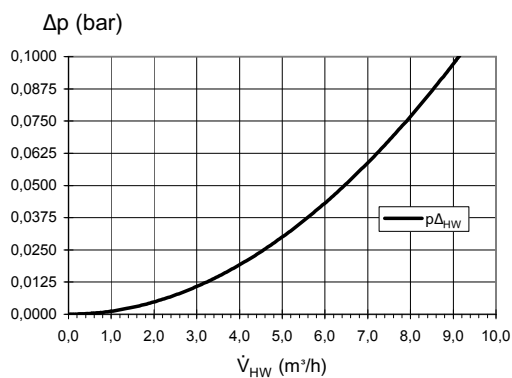
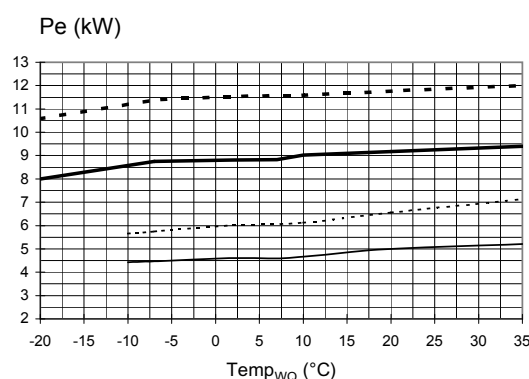
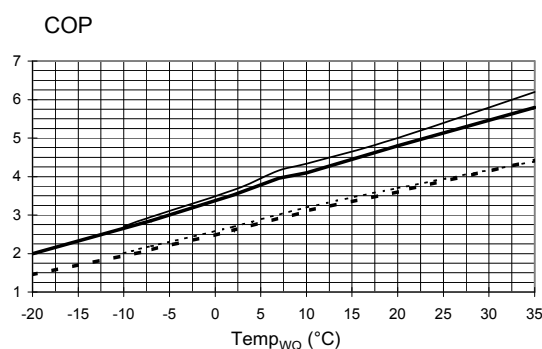
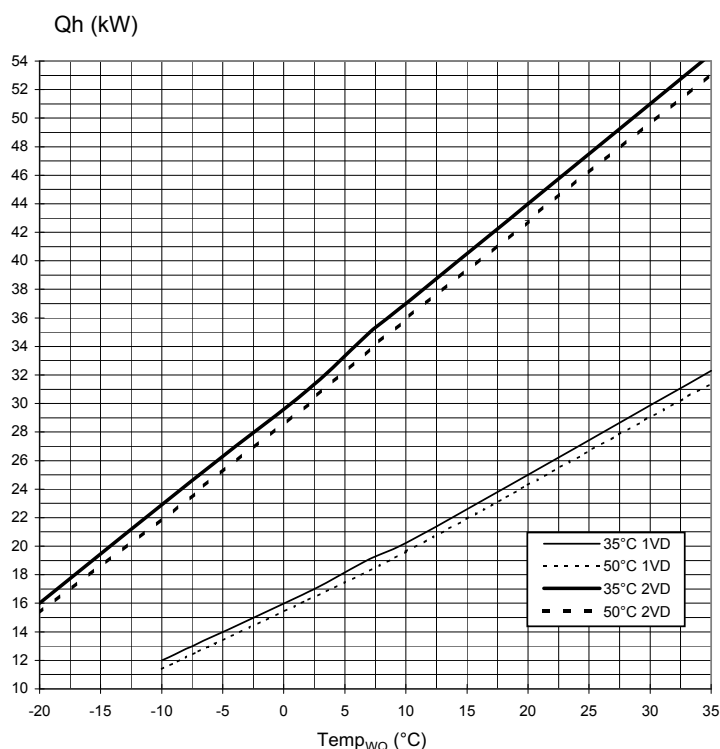

823147a

Legend:	UK823129L/170408
\dot{V}_{HW}	Volume flow, heating water
Temp _{WQ}	Temperature, heat source
Q _h	Heating capacity
Pe	Power consumption
COP	Coefficient of performance / efficiency rating
Δp_{HW}	Pressure loss heat pump
VD	Compressor(s)



LW 71A – LW 81A

Dimensional drawings

A

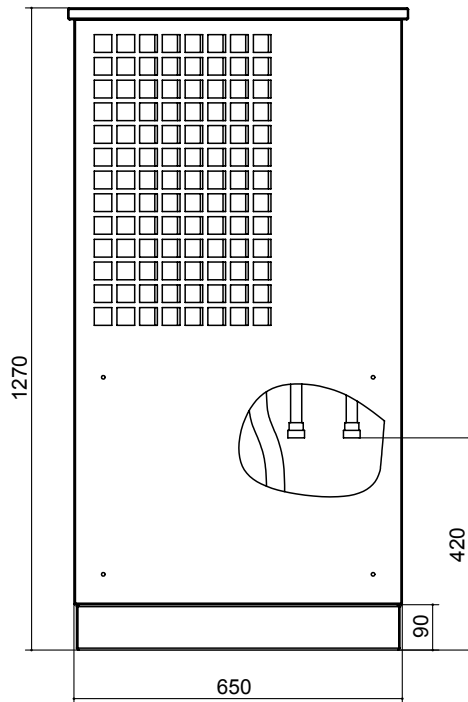

B

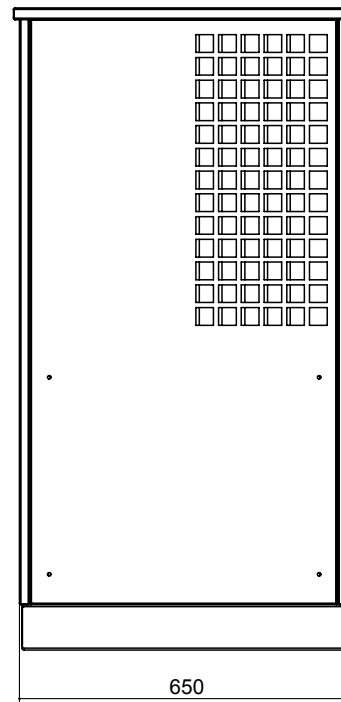

C

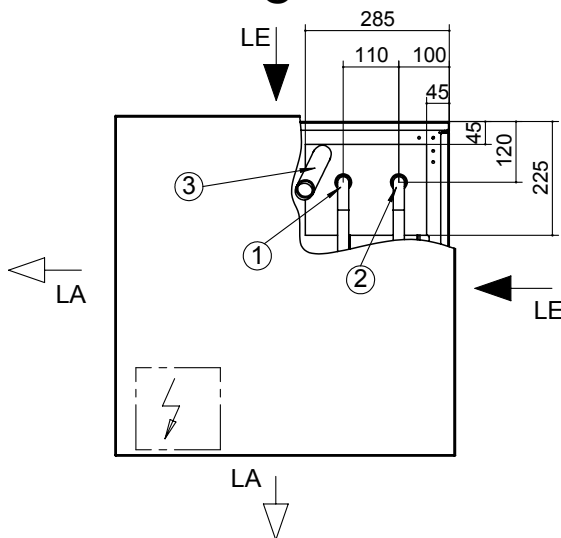

Legend: UK819373

All dimensions in mm.

A Front view

B Side view

C Top view

1 Hot water outflow (forward flow) R1"

2 Hot water inflow (return flow) R1"

3 Condensate hose diameter 36 mm

LE Air inflow

LA Air outflow



Dimensional drawings

LW 101A

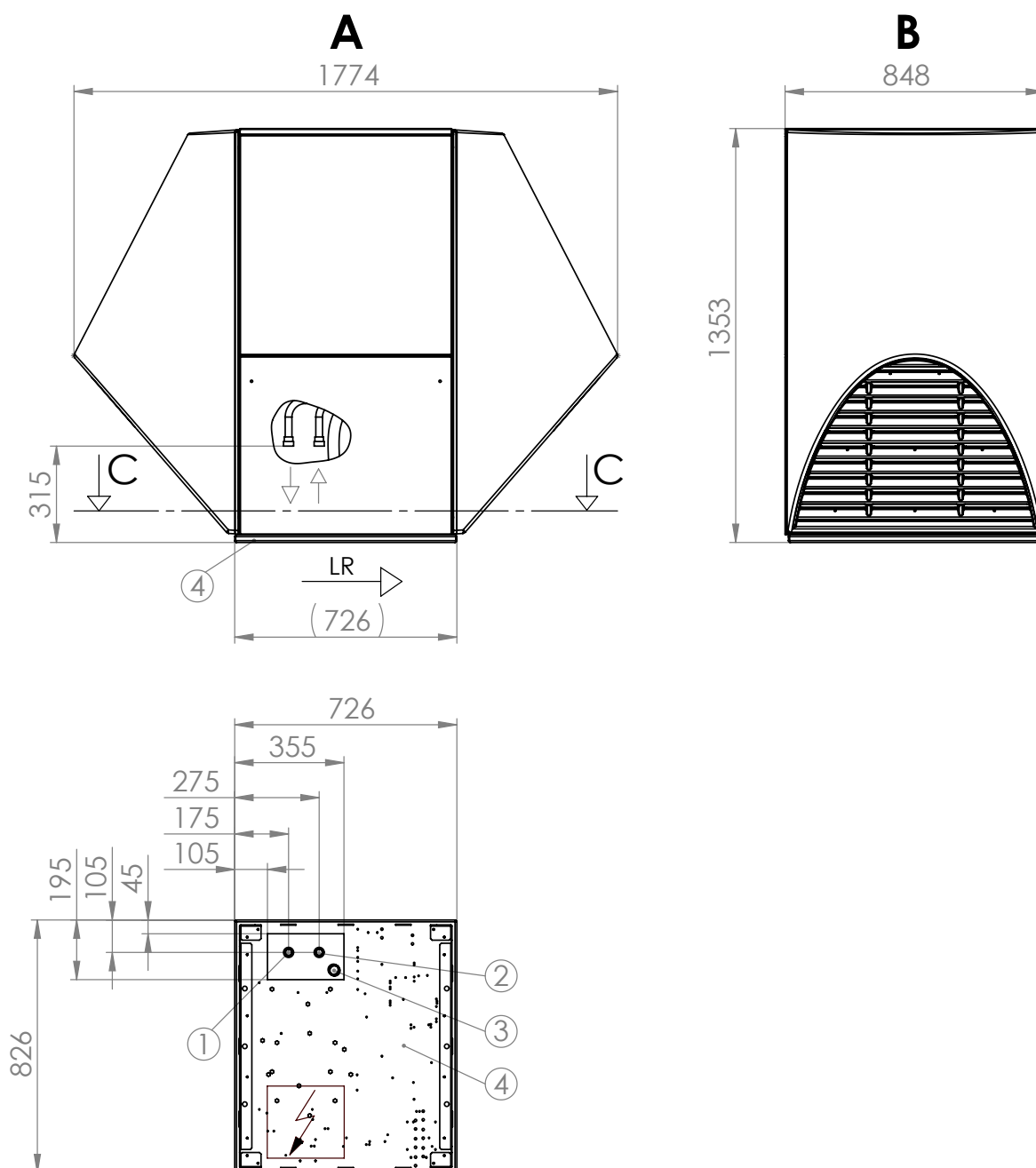

Key: UK819351d
Subject to technical change without notice.
All dimensions in mm.

- A Front view
- B Side view from left
- C Plan view
(Section, without façade and shrouds)

- 1 Heating water outlet (flow) R 1"
- 2 Heating water inlet (return) R 1"
- 3 Condensate hose, outside - 36x3
- 4 Baseplate
- LR Air direction



LW 121A

Dimensional drawings

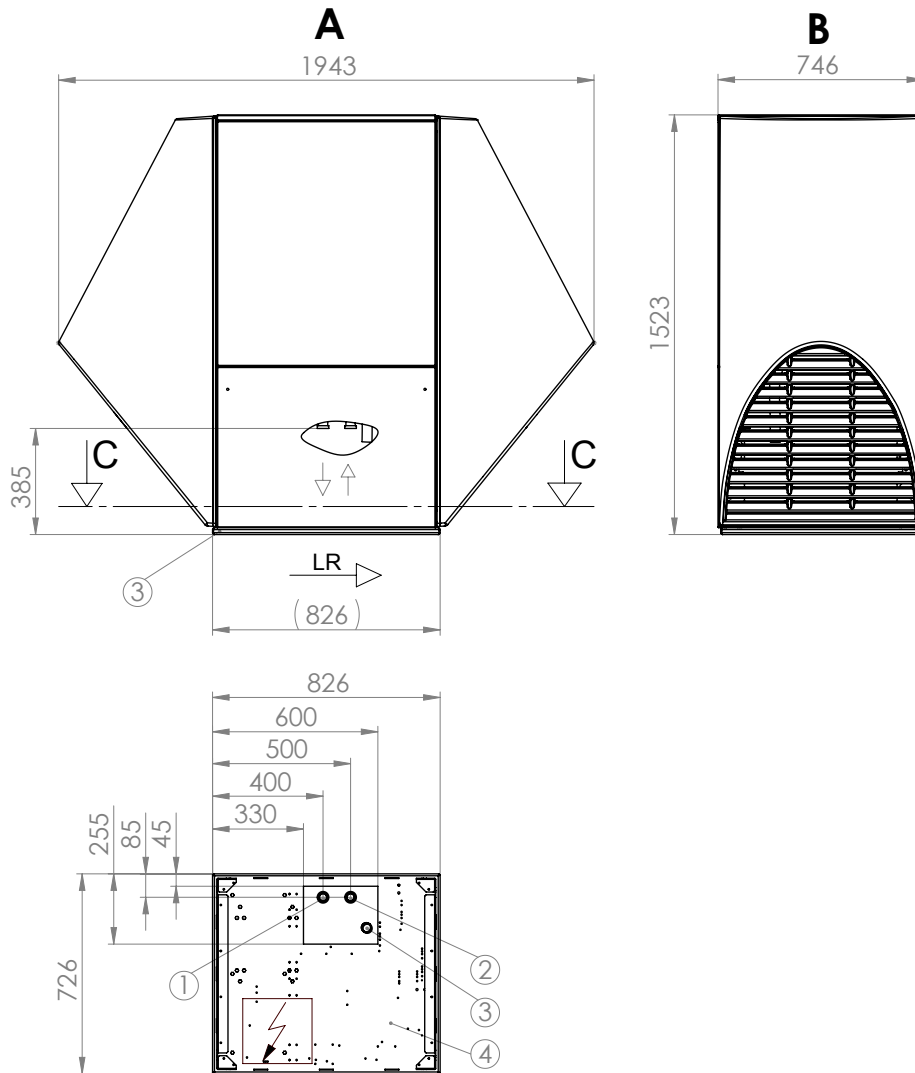

Key: UK819435

Subject to technical change without notice.

All dimensions in mm.

- A Front view
- B Side view
- C Plan view
(Section, without façade and shrouds)

- 1 Heating water outlet (flow) R 1"
- 2 Heating water inlet (return) R 1"
- 3 Condensate hose, outside \varnothing 36x3
- 4 Baseplate
- LR Air direction



Dimensional drawings

LW 140A – LW 180A

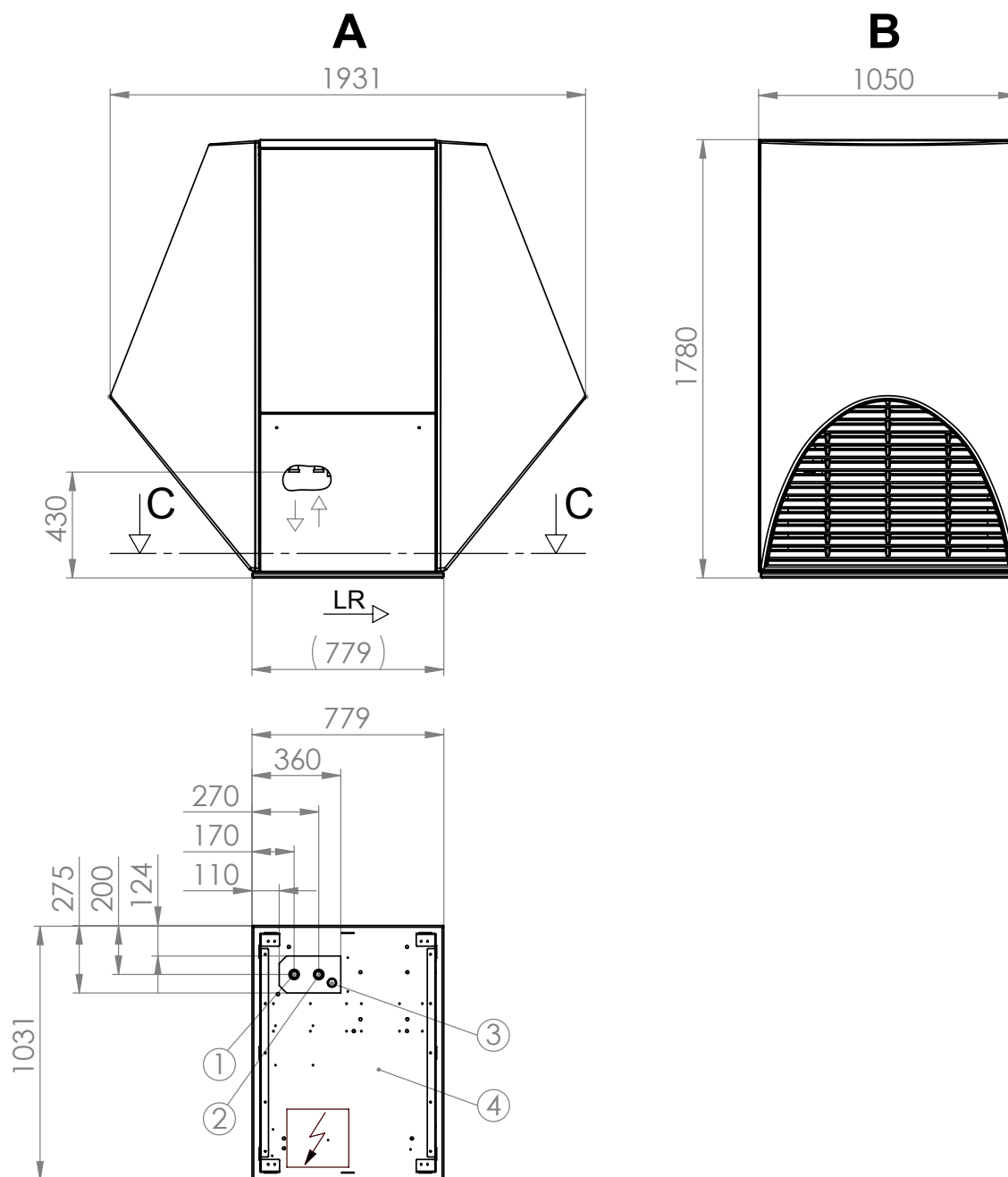

Key: UK819436

Subject to technical change without notice.

All dimensions in mm.

- A Front view
- B Side view
- C Plan view
(Section, without façade and shrouds)

- 1 Heating water outlet (flow) R 1 1/4"
- 2 Heating water inlet (return) R 1 1/4"
- 3 Condensate hose, outside -<MOD-DIAM> 36x3
- 4 Baseplate
- LR Air direction



LW 251A

Dimensional drawings

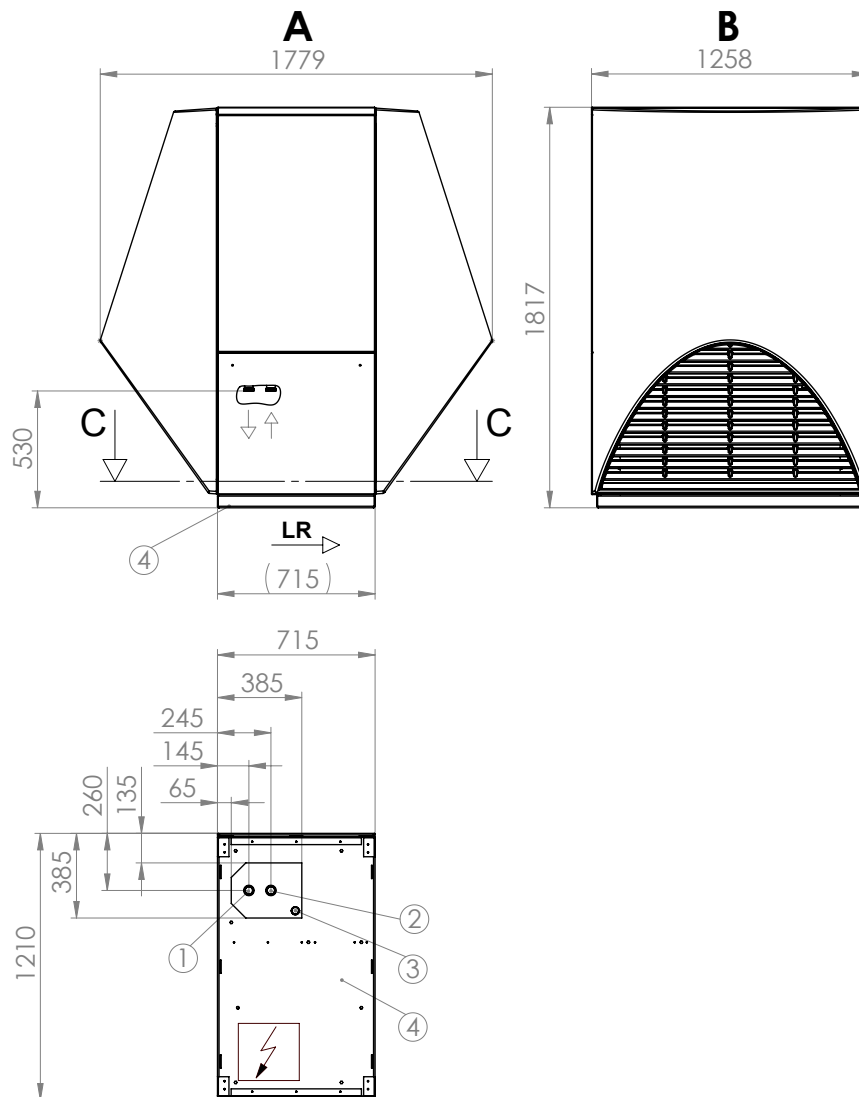

Key: UK819437

Subject to technical change without notice.

All dimensions in mm.

- A Front view
- B Side view
- C Plan view
(Section, without façade and shrouds)

- 1 Heating water outlet (flow) R 1 1/4"
- 2 Heating water inlet (return) R 1 1/4"
- 3 Condensate hose, outside - 36x3
- 4 Baseplate
- LR Air direction



Dimensional drawings

LW 310A

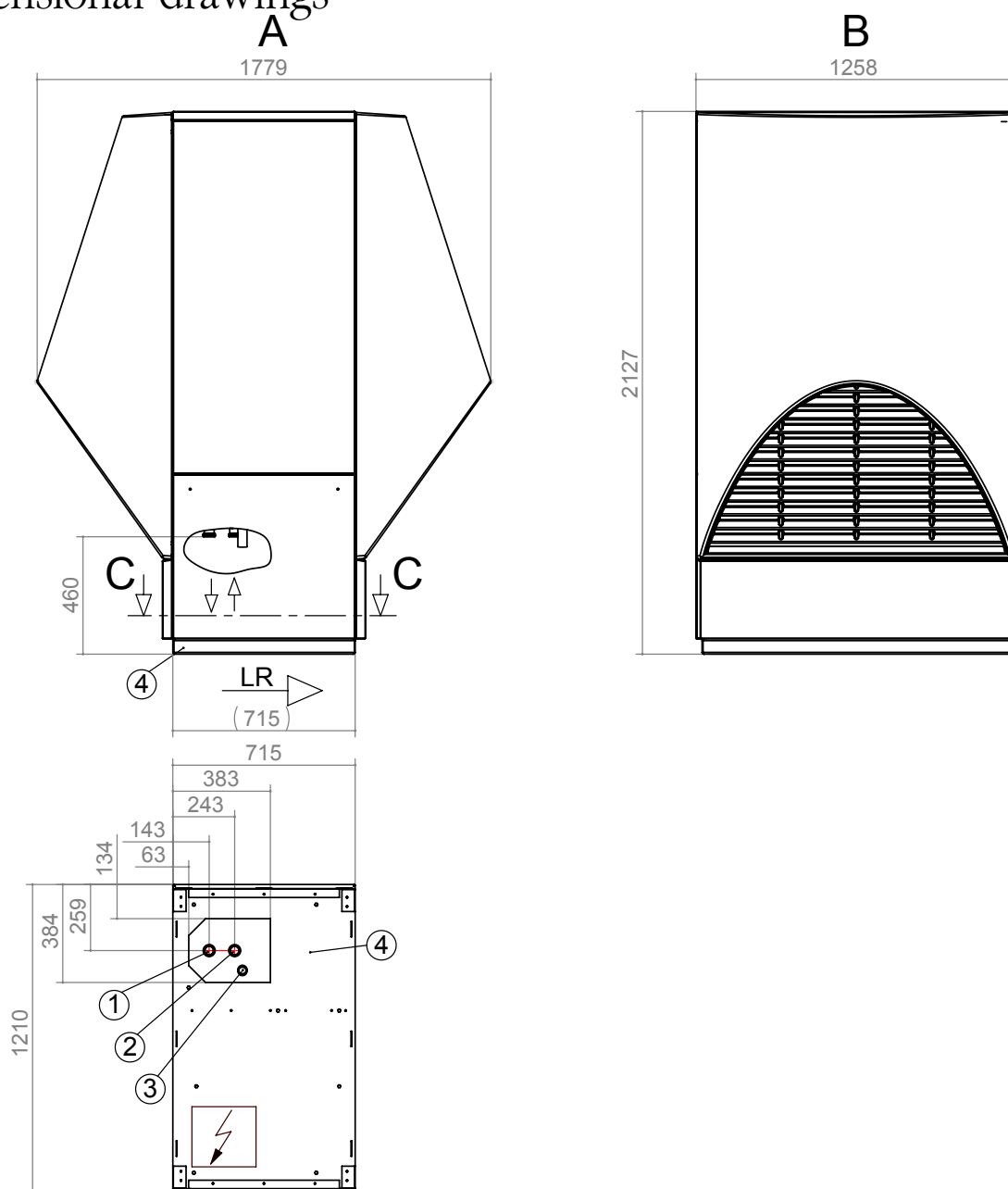

Key: UK819326b

Subject to technical change without notice.

All dimensions in mm.

- A Front view
- B Side view
- C Plan view (section, without façade and shrouds)

- 1 Heating water outlet (flow) R 1 1/2"
 - 2 Heating water inlet (return) R 1 1/2"
 - 3 Condensate hose, outside Ø 36x3
 - 4 Baseplate
- LR Air direction
LR Luftrichtung



LW 71A – LW 81A

Installation plan

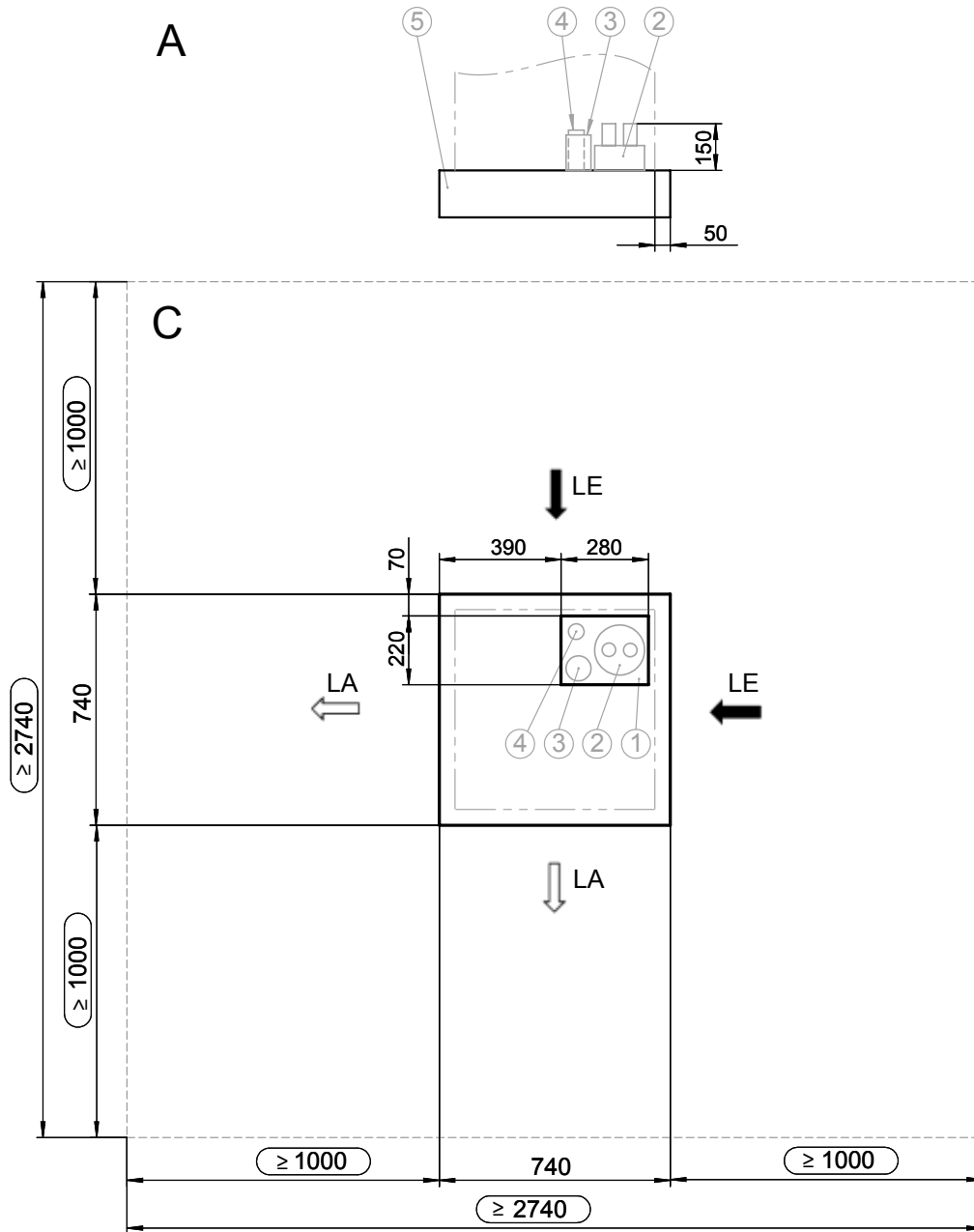

Legend: UK819374a

All dimensions in mm.

- A Front view
- C Top view
- - - - Unit contour
- ≥ ... Minimum clearances
- 1 Recess in base
- 2 Local heat pipe for heating water forward/return flow *)
- 3 Empty pipe for electric cables, minimum diameter 70mm *)
- 4 Condensate discharge, minimum diameter 50mm *)
- 5 Base
- LE Air inflow
- LA Air outflow
- *) see planning documents



Installation plan

LW 101A

A

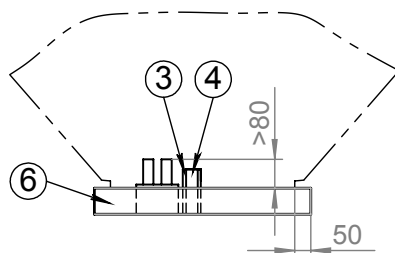

C

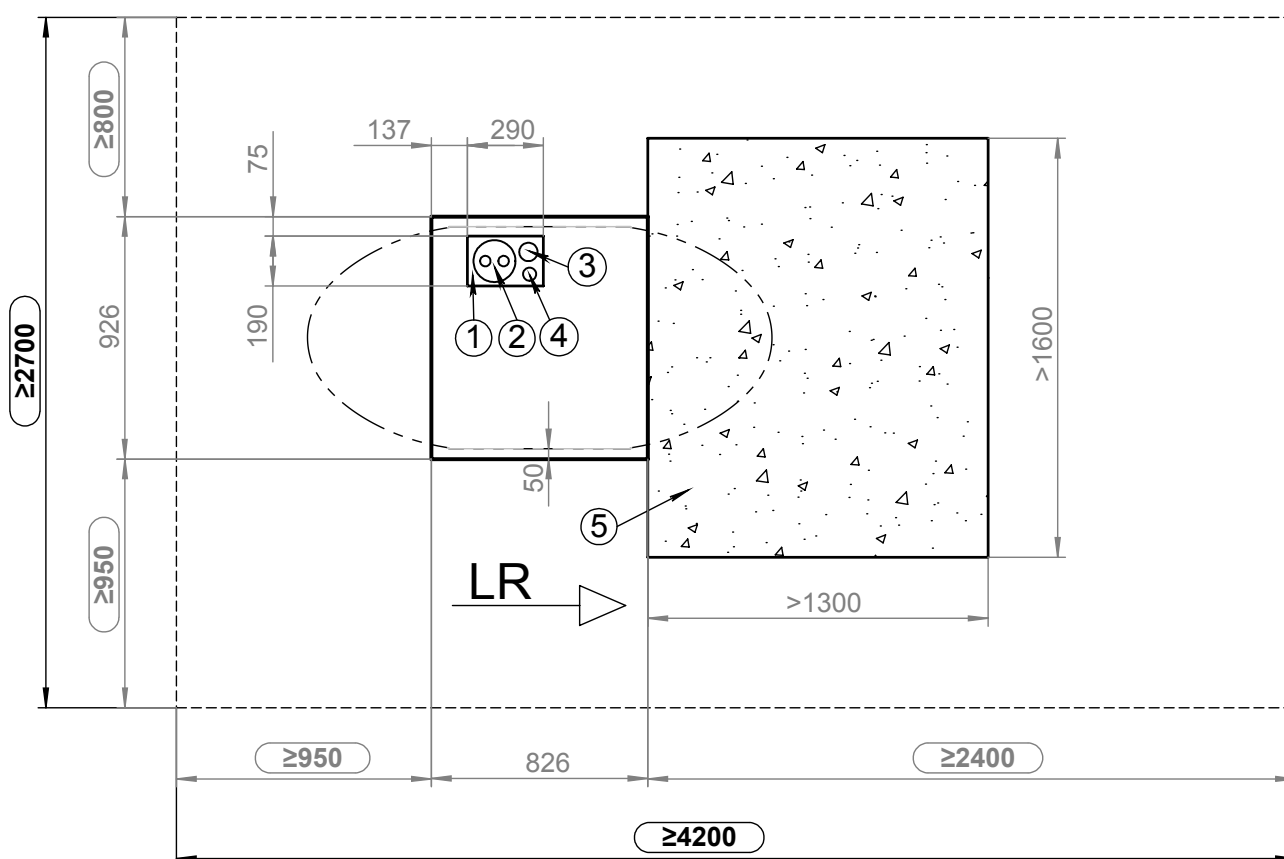

Legend: UK819375a

All dimensions in mm.

A Front view

C Top view

≥ ... Minimum clearances

1 Recess in base

2 Local heat pipe for heating water forward/return flow

3 Empty pipe for electric cables, minimum diameter 70mm

4 Condensate discharge, minimum diameter 50mm

5 Water-permeable surface (gravel, ...) in the air outlet area

6 Base

LR Air direction



LW 121A

Installation plan

A

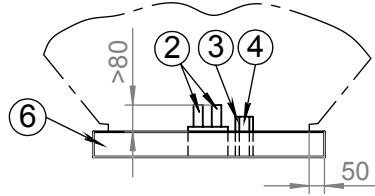

C

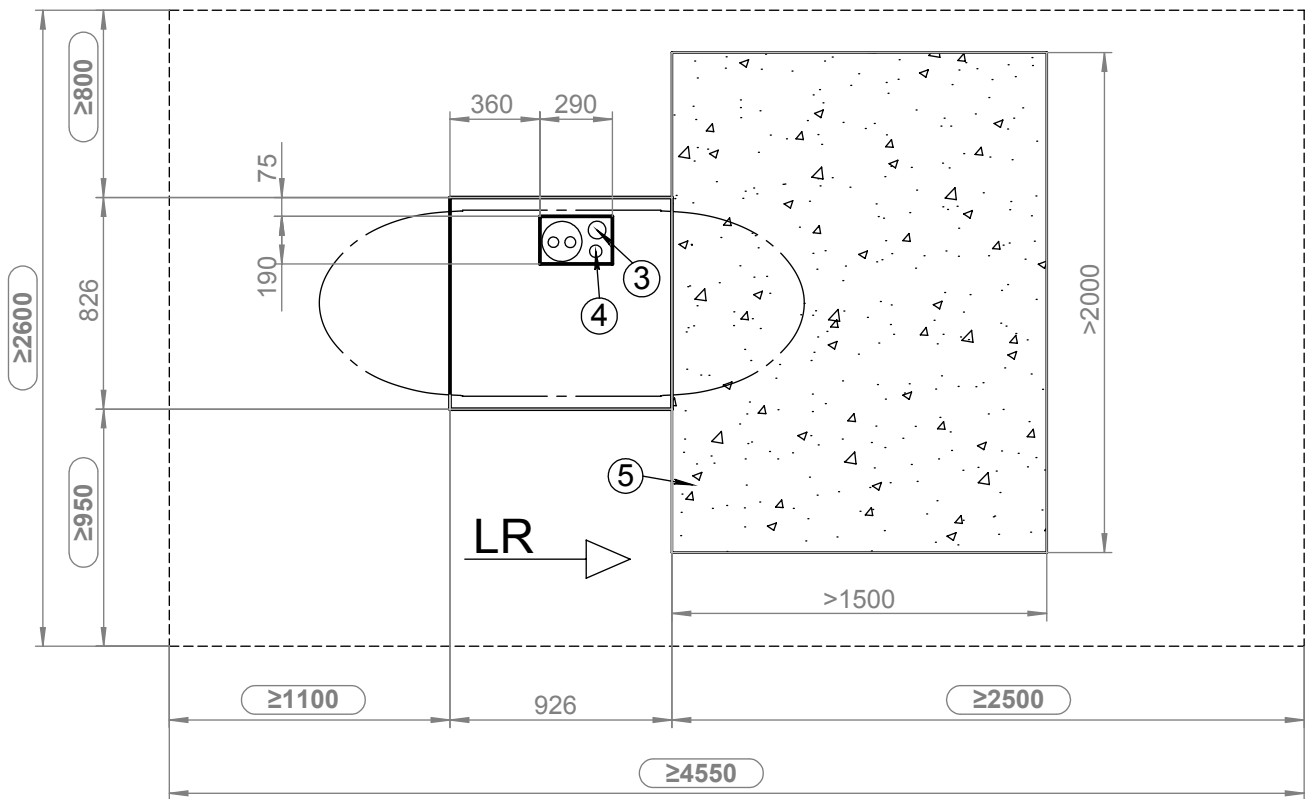

Legend: UK819376

All dimensions in mm.

A Front view

C Top view

≥ ... Minimum clearances

1 Recess in base

2 Local heat pipe for heating water forward/return flow

3 Empty pipe for electric cables, minimum diameter 70mm

4 Condensate discharge, minimum diameter 50mm

5 Water-permeable surface (gravel, ...) in the air outlet area

6 Base

LR Air direction



Installation plan

LW 140A – LW 180A

A

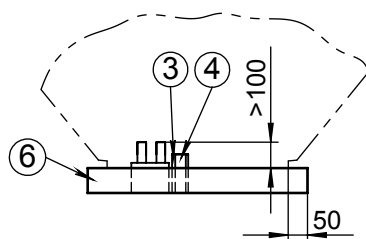

C

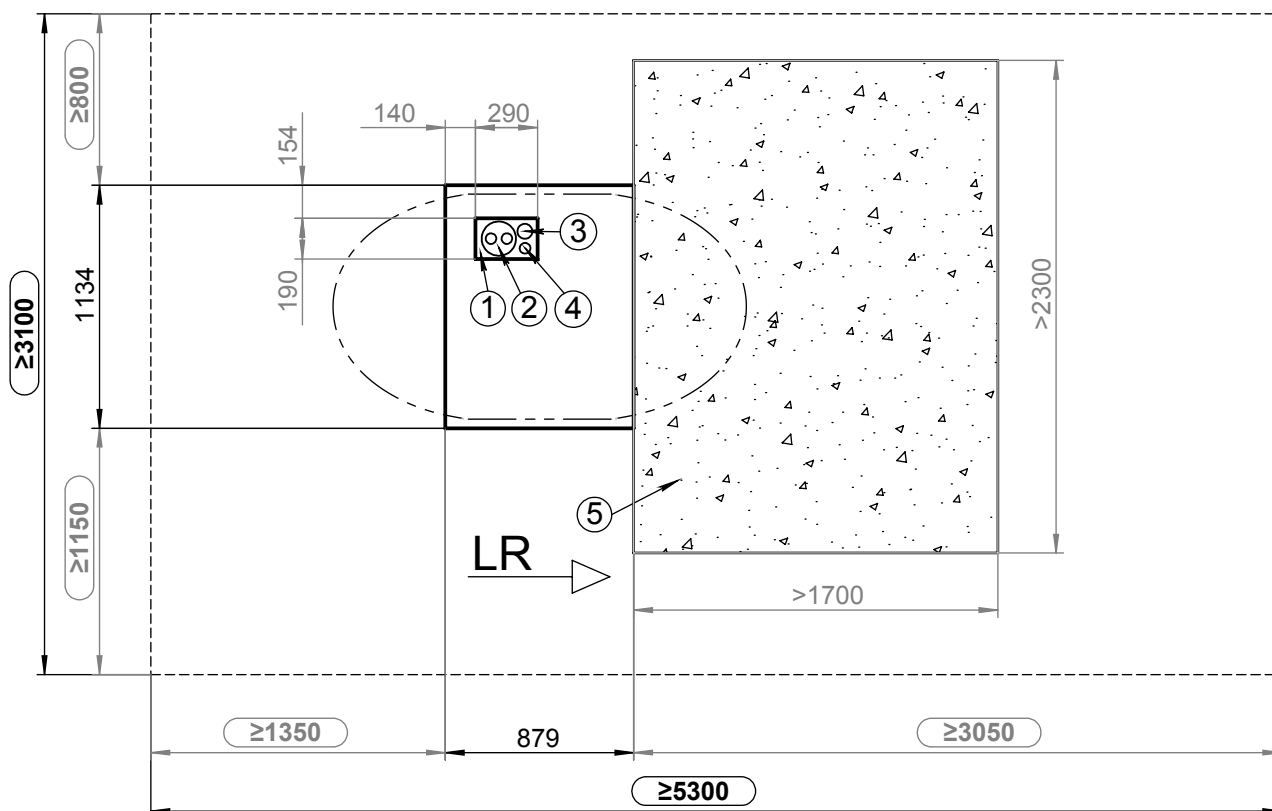

Legend: UK819377a

All dimensions in mm.

A Front view

C Top view

≥ ... Minimum clearances

1 Recess in base

2 Local heat pipe for heating water forward/return flow

3 Empty pipe for electric cables, minimum diameter 70mm

4 Condensate discharge, minimum diameter 50mm

5 Water-permeable surface (gravel, ...) in the air outlet area

6 Base

LR Air direction



LW 251A

Installation plan

A

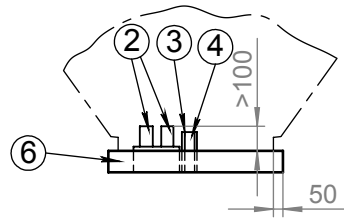

C

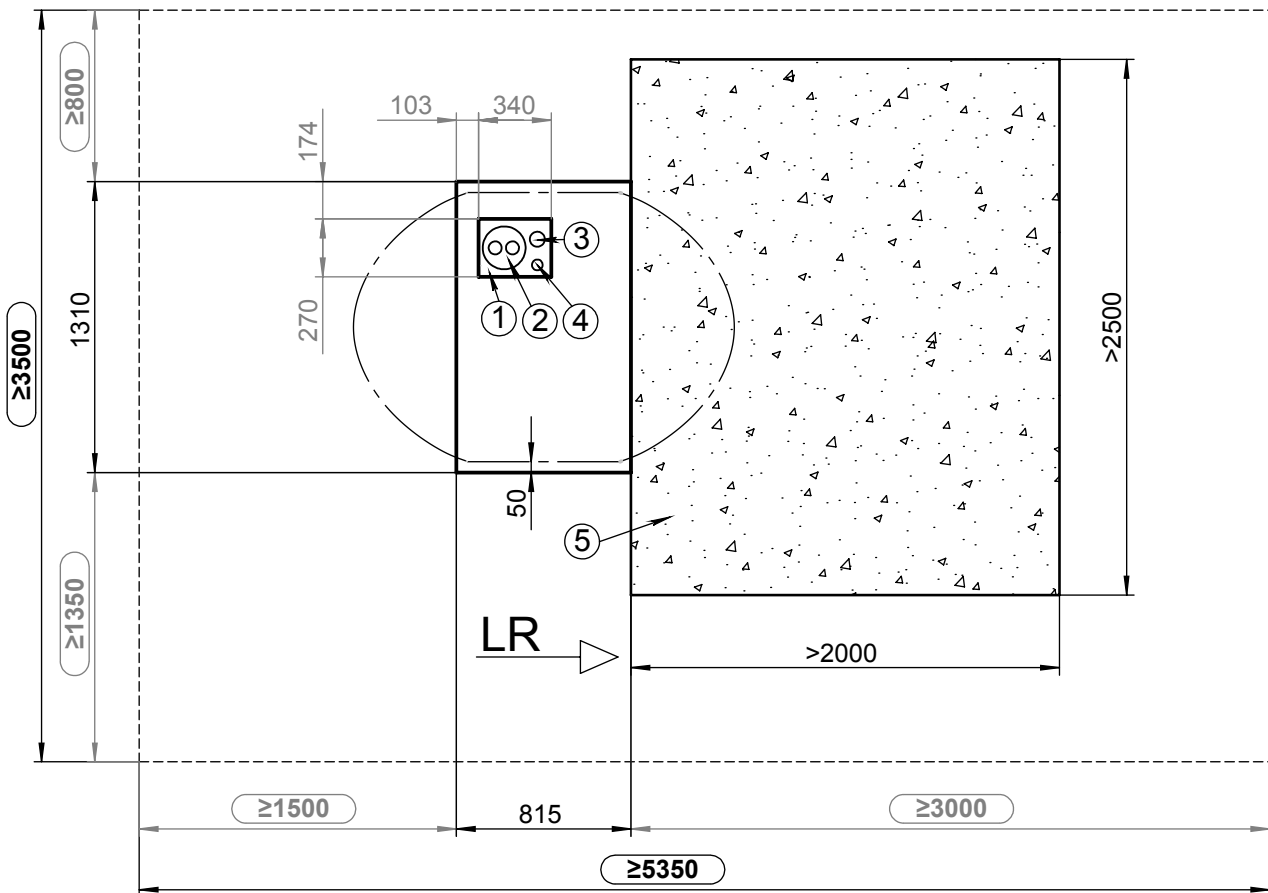

Legend: UK819378

All dimensions in mm.

A Front view

C Top view

≥ ... Minimum clearances

1 Recess in base

2 Local heat pipe for heating water forward/return flow

3 Empty pipe for electric cables, minimum diameter 70mm

4 Condensate discharge, minimum diameter 50mm

5 Water-permeable surface (gravel, ...) in the air outlet area

6 Base

LR Air direction



Installation plan

LW 310A

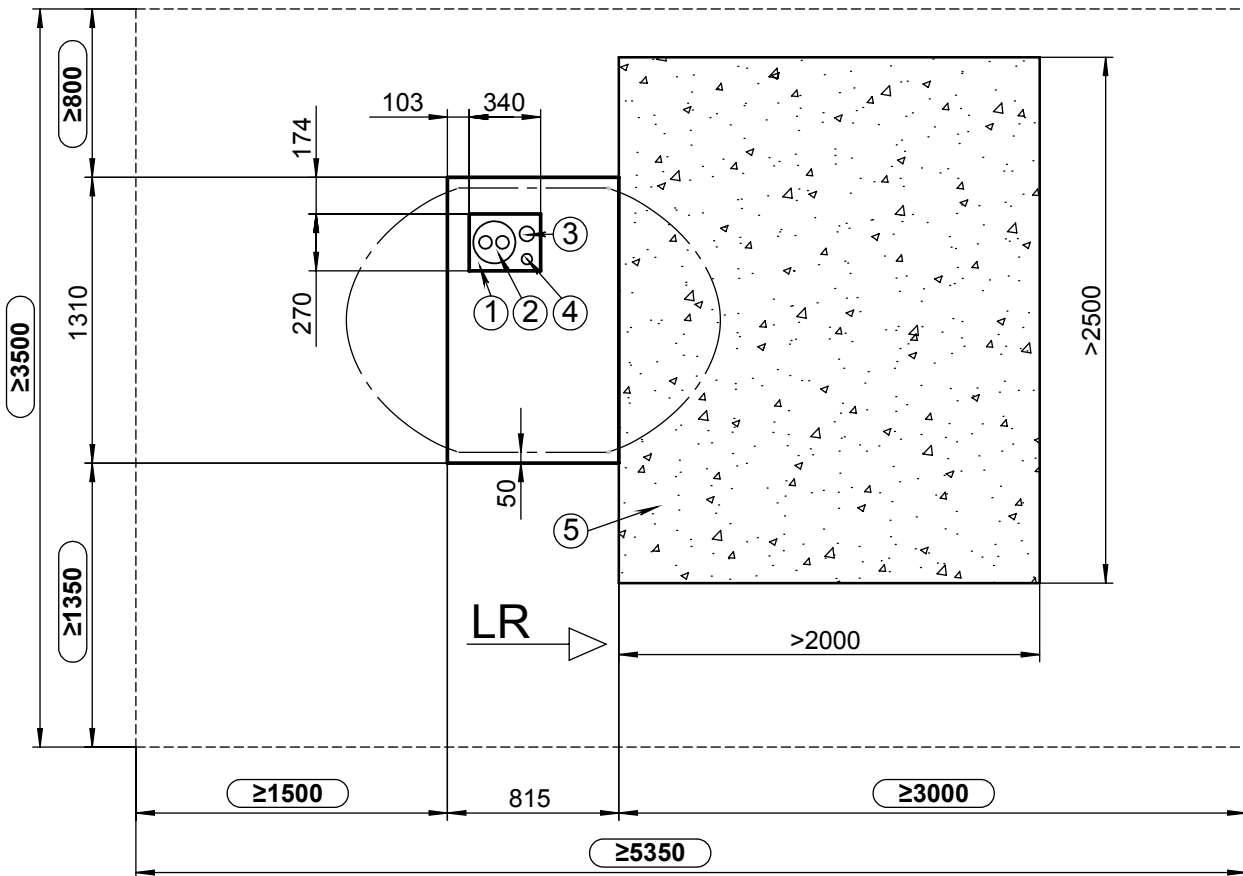
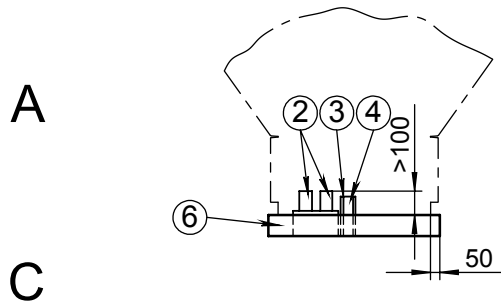

Legend: UK819327

All dimensions in mm.

A Front view

C Top view

≥ ... Minimum clearances

1 Recess in base

2 Local heat pipe for heating water forward/return flow

3 Empty pipe for electric cables, minimum diameter 70mm

4 Condensate discharge, minimum diameter 50mm

5 Water-permeable surface (gravel, ...) in the air outlet area

6 Base

LR Air direction

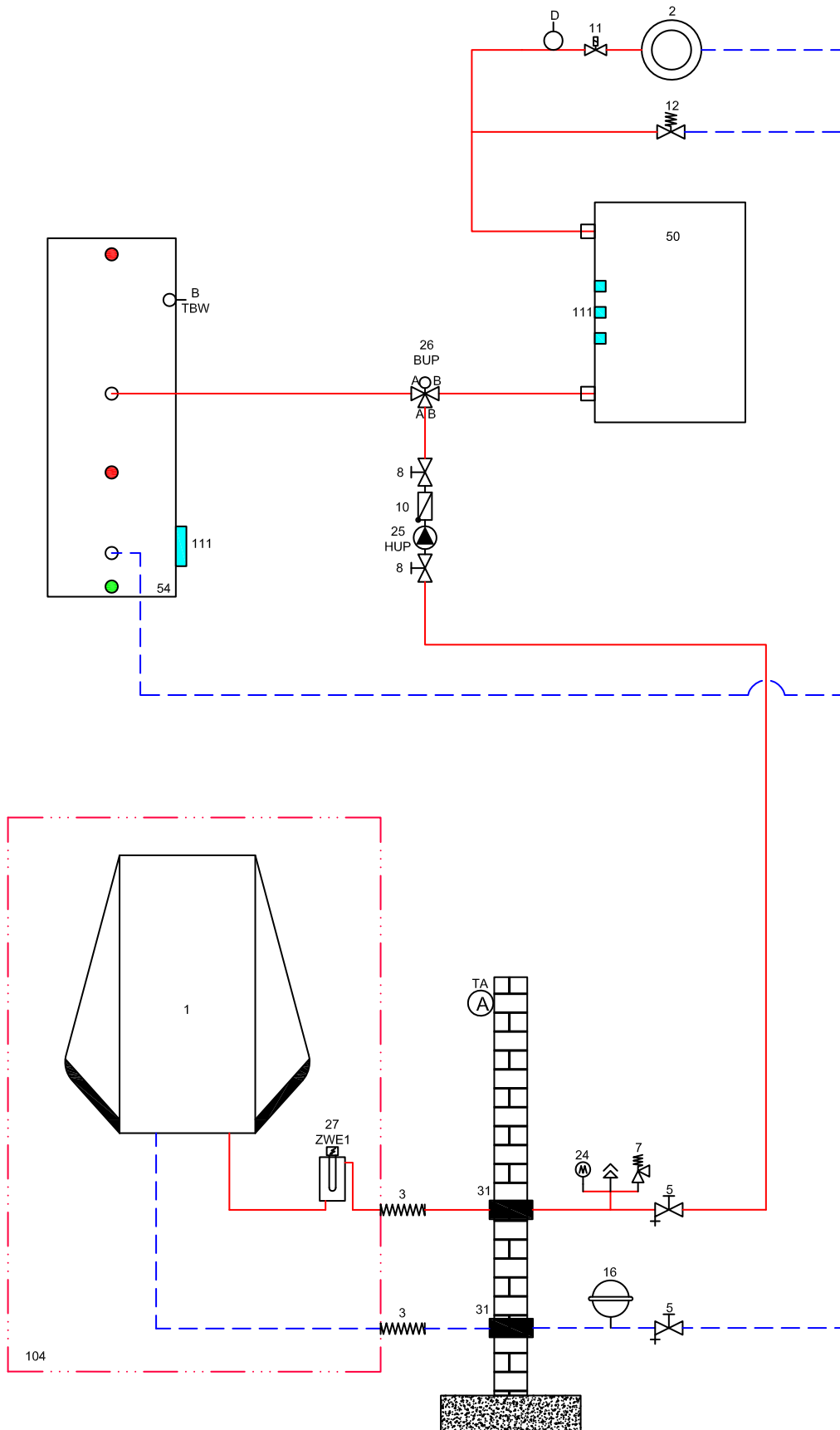



Separate buffer tank

LW 71A – LW 251A

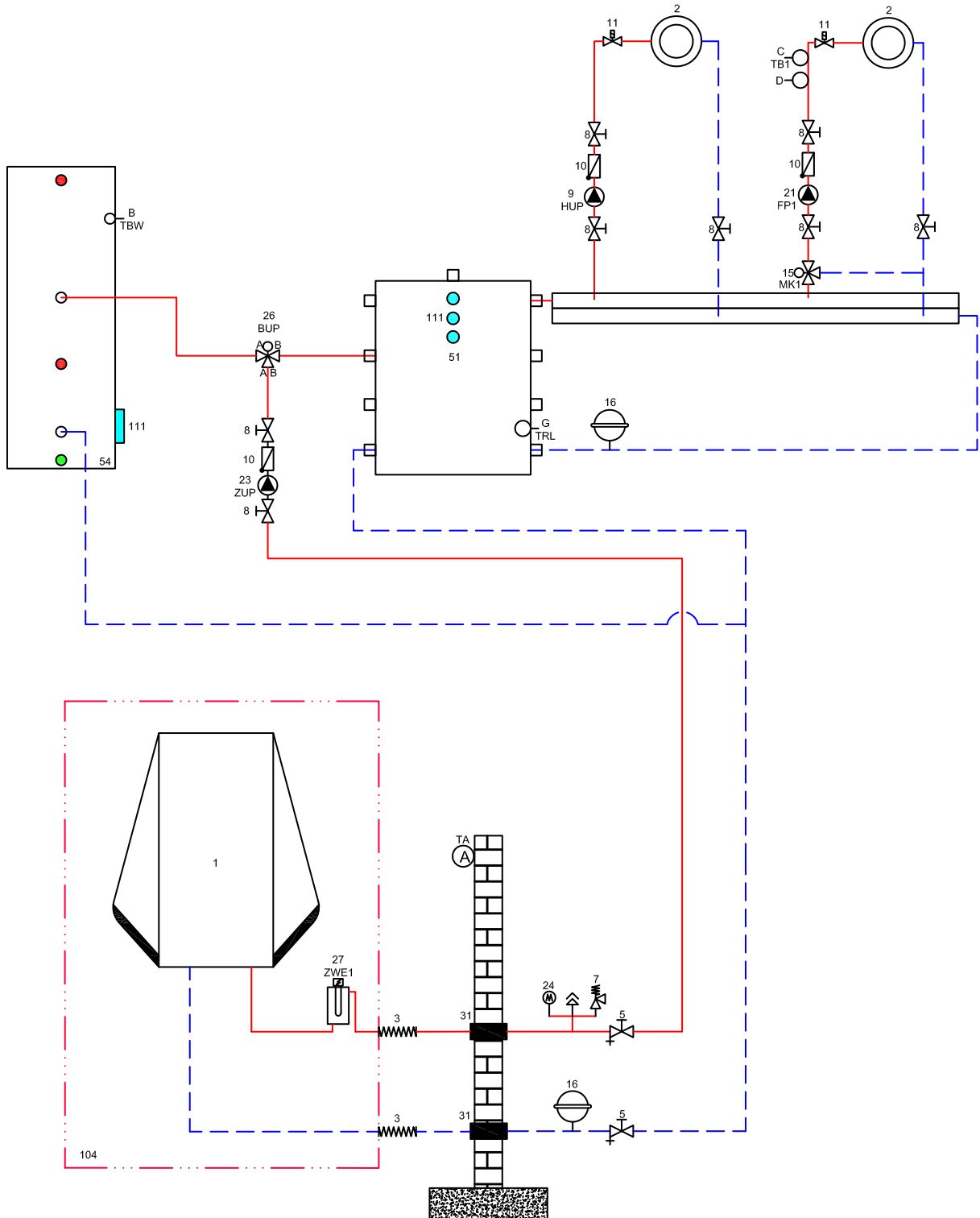

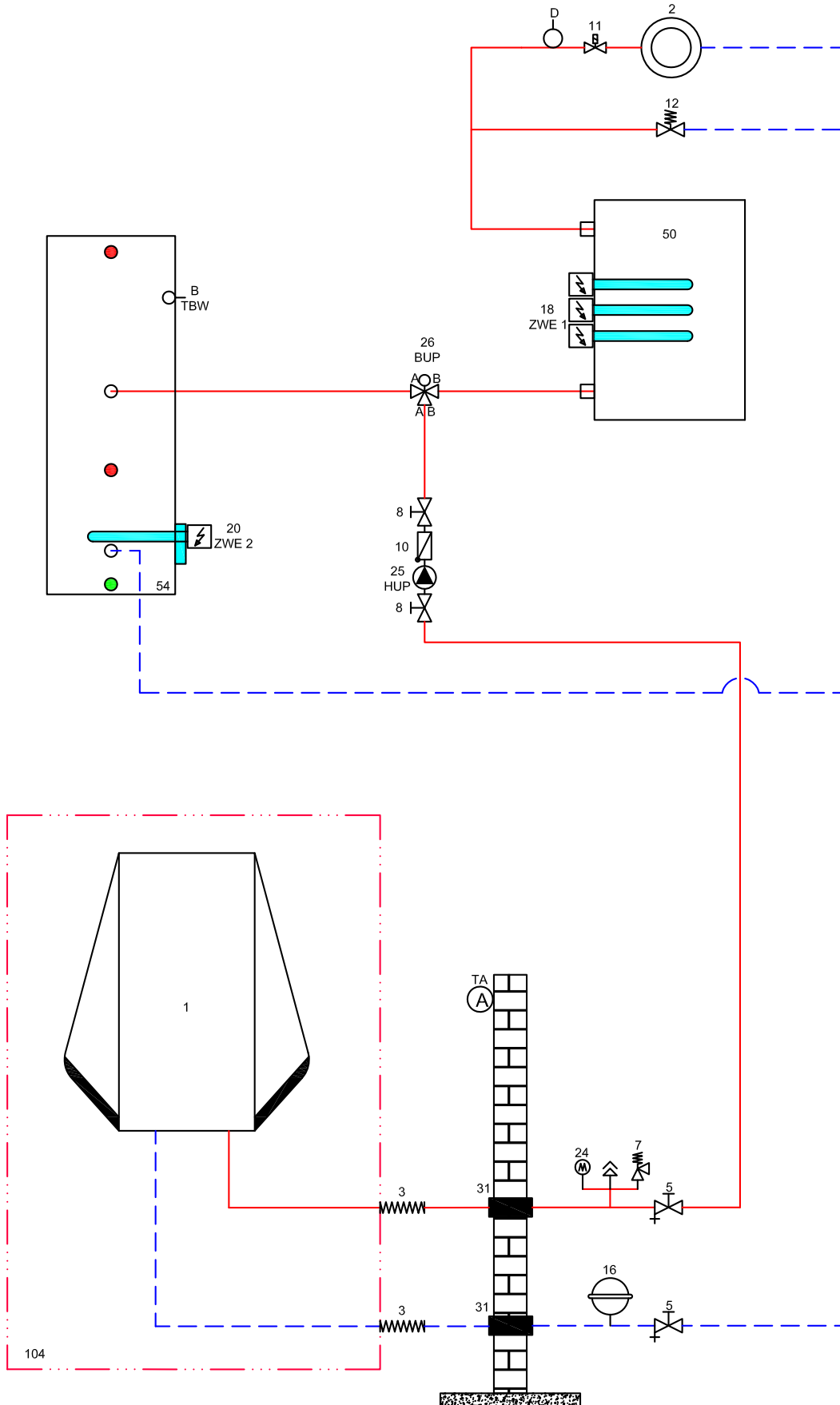



Separate buffer tank

LW 310A

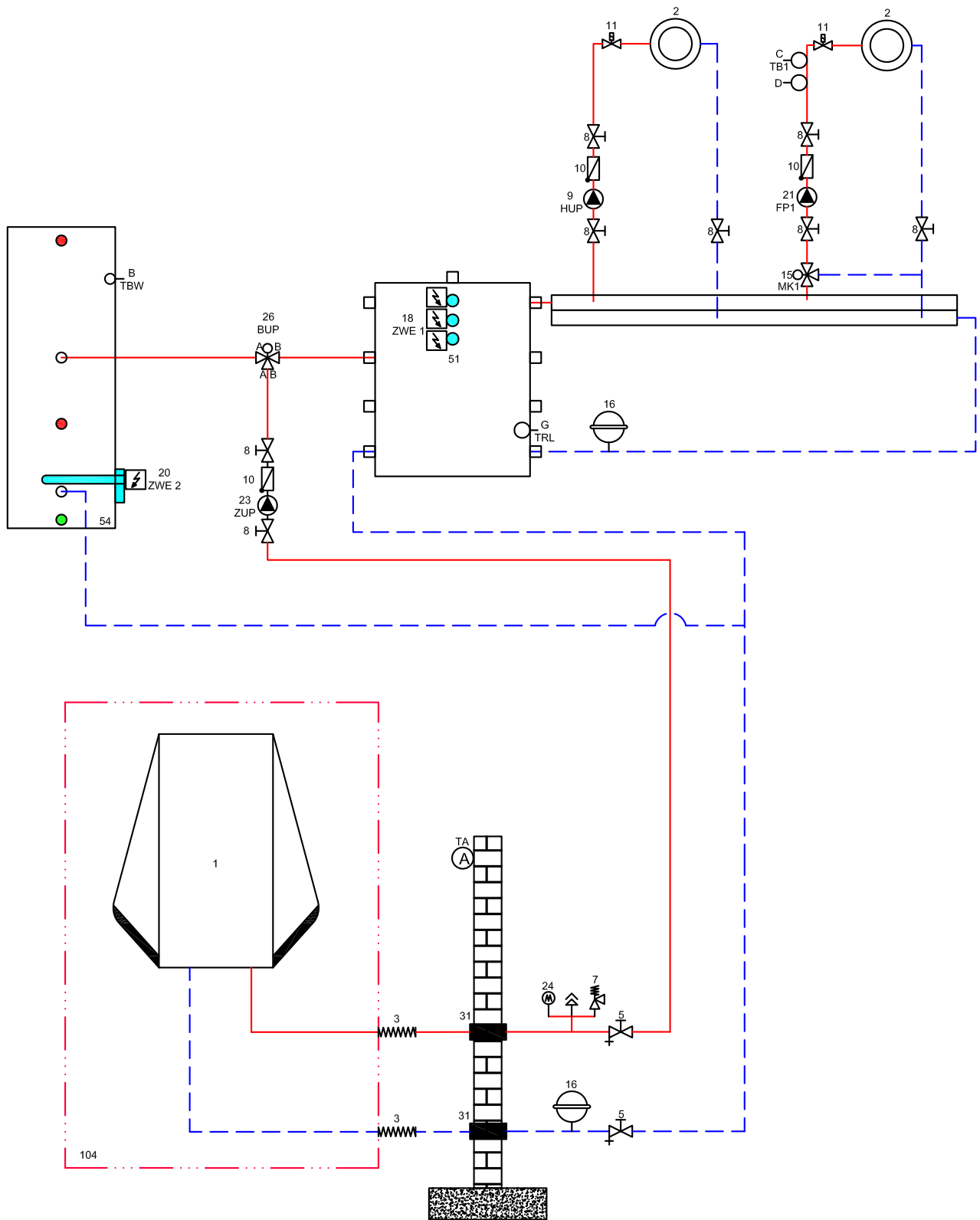



Legend hydraulic diagramm

1	Heat pump
2	Underfloor heating / radiators
3	Vibration isolation
4	Sylomer strip machine underlay
5	Closure and drainage
6	Expansion vessel packing list
7	Safety valve
8	Closure
9	Heating circulation pump
10	Non return valve/ one way valve
11	Individual room regulation
12	Overflow valve
13	Steamtight insulation
14	Service water circulation pump
15	Mixer circuit three-way mixer (MK1 discharge)
16	Expansion vessel supplied by customer
18	Heating rod (heating)
19	Mixer circuit four-way mixer (MK1 charge)
20	Heating rod (SW)
21	Mixer circuit circulation pump (FP-1)
23	Feed circulating pump (reconnect the integrated circulating pump in the heat pump)
24	Manifold
25	Heating circulation pump
26	Switching valve (heating/service water)(B = normally open)
27	Heating element
28	Brine circulation pump
29	Dirt-trap 0.6 mm mesh
30	Spill-tray for brine mix
31	Wall breakthrough
32	Inlet pipe
33	Brine manifold
34	Ground collector
35	Ground slinkies
36	Groundwater spring pump
37	Wall bracket
38	Flow switch
39	Suction well
40	Inverted well
41	Rinse fitting heating circuit
42	Circulation pump
43	Brine / Water heat exchanger (cooling function)
44	Three-way mixer valve (cooling function MK1)
45	Cap valve
46	Filler and drainage valve
48	Domestic hot water charging pump
49	Direction of groundwater flow
50	Buffer storage

51	Seperation tank
52	Gas- or oil-boiler
53	Wood boiler
54	Hot water cylinder
55	Brine pressure switch
56	Swimming pool heat exchanger
57	Geothermal heat exchanger
58	Ventilation system
59	Plate heat exchanger
61	Cooling cylinder
65	Compact distributor
66	Fancoils
67	Solar/ service water cylinder
68	Solar/ service water cylinder
69	Multifunction tank
71	Dual hydraulic module
72	Buffer tank wall mounted
73	Pipe lead-in
74	Venttower
75	Scope of delivery, hydraulic tower, dual
76	Fresh water station
77	Scope of supply water/water booster
78	Accessories water/water booster optional

TAVA	External sensor
TBWB	Domestic hot water sensor
TB1/C	Feedwater sensor mixer circuits 1
D	Floor temperature limiter
TRL/G	Sensor external return
STA	Line pressure regulator valve
TRL/H	Sensor return (hydraulic module, dual)
79	Motor valve
80	Mixing valve
81	Split heat pump outdoor unit
82	Split heat pump indoor unit
83	Circulation pump
84	Switching valve
113	Connection 2nd heat generator
BT1	Outdoor temperature sensor
BT2	Flow temperature sensor
BT3	Return temperature sensor
BT6	Domestic hot water temperature sensor
BT12	Flow temperature liquefier
BT19	Temperature sensor immersion heater
BT24	Temperature sensor 2nd heat generator

Comfort board:

15	Mixer circuit three-way mixer (MK2-3 discharge)
17	Temperature difference regulator
19	Mixer circuit four-way mixer (MK2 charge)
21	Mixer circuit circulation pump (FP2-3)
22	Swimming pool circulating pump
44	Three-way mixer valve (cooling function MK2)
47	Changeover valve swimming bath preparation(B = normally open)
60	Changeover valve cooling operation(B = normally open)
62	Heat meter (optional)
63	Changeover valve solar circuit(B = normally open)
64	Cooling circulation pump
70	Solar separation module
TB2-3/C	Feedwater sensor mixer circuits 2-3
TSS/E	Sensor, temperature difference control (low temperature)
TSK/E	Sensor, temperature difference control (high temperature)
TEE/F	Sensor external energy source

100	Room thermostat for cooling (optional)
101	Controls supplied by customer
102	Dew-point monitor (optional)
103	Room thermostat for reference space in packing list
104	Supply heat pump
105	Cooling circuit module box removeable for installation
106	Specific glycole mixture
107	Scald protection / thermostatic mixer valve
108	Solar pump assembly
109	Overflow valve must be closed
110	Packing list hydraulic tower
111	Mounting for additional heating element
112	Minimum distance to thermal decoupling of the mixing valve

Important notice !

These hydraulic diagrams are schematic representations and are for assistance only. They do not relieve of the obligation to carry out appropriate planning! They do not include all necessary shut-off valves, ventilator fittings or safety devices. These must be incorporated in accordance with the standards and regulations applicable to the respective installation. All country-specific standards, laws and regulations must be observed! The tubes have to be dimensioned according to the nominal volume flow of the heat pump resp. the free pressing of the integrated circulating pump. For detailed information and advice please contact our local sales partner!



LW 71A – LW 81A

Terminal diagram

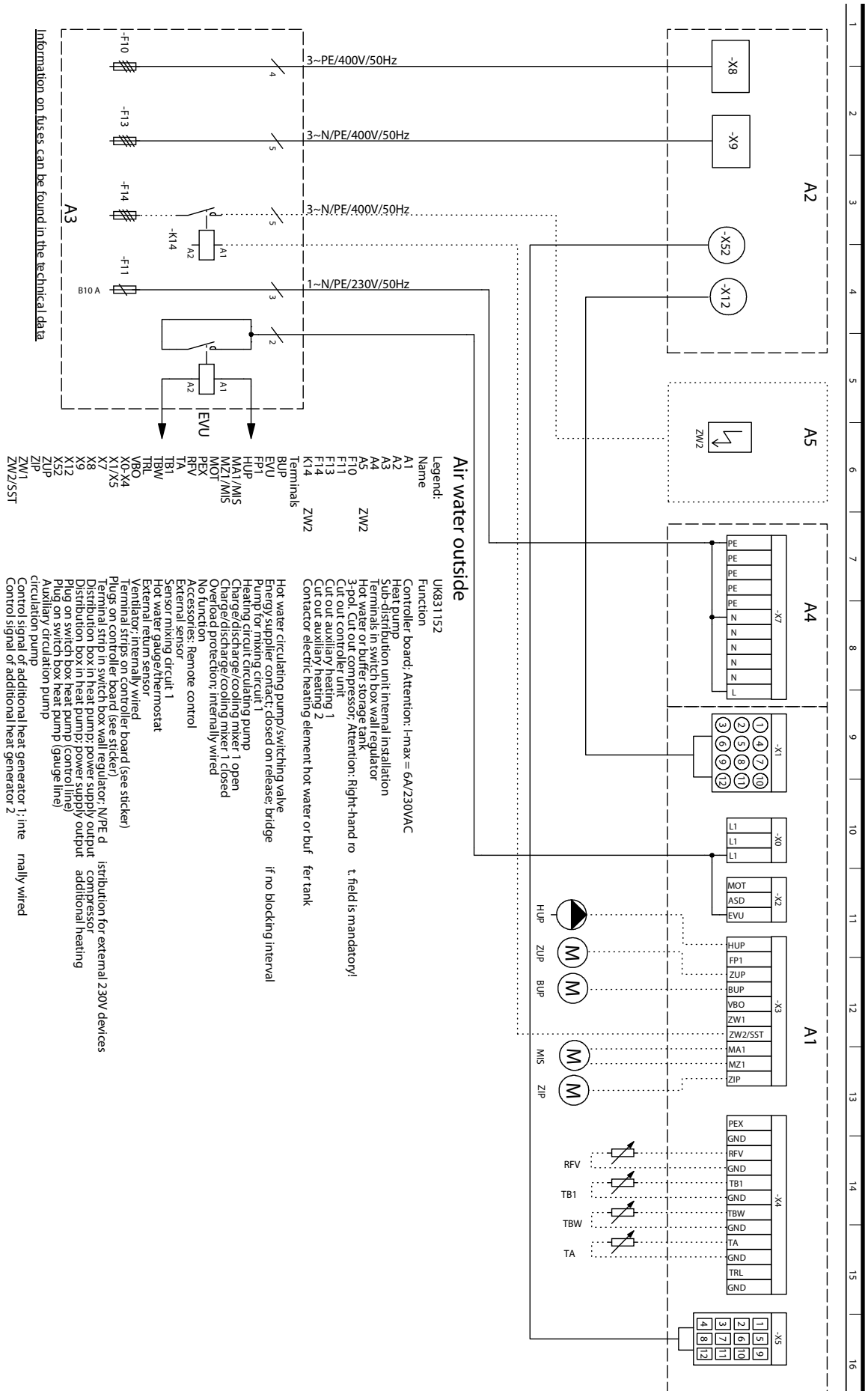



LW 101A – LW 251A

Terminal diagram

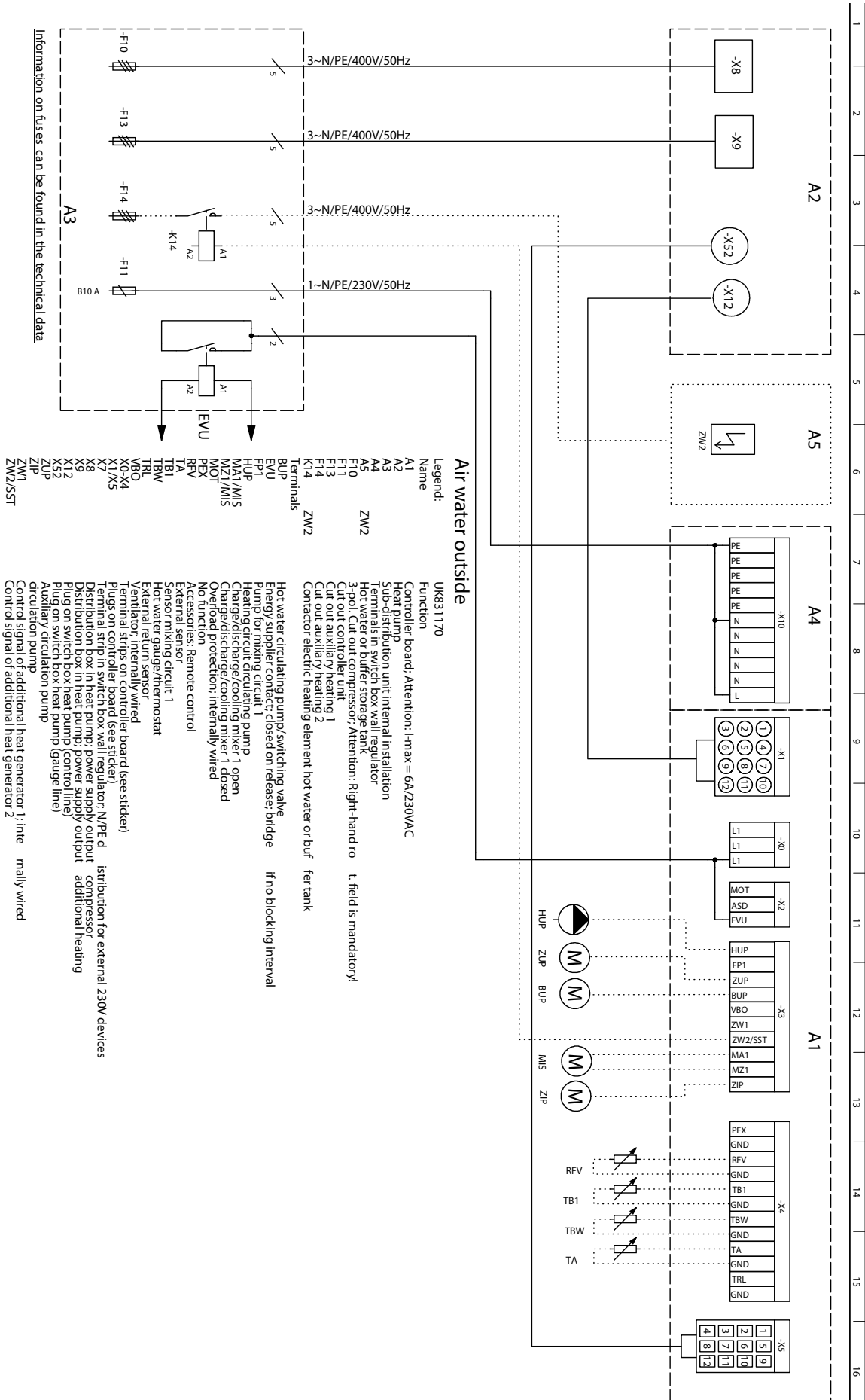



Terminal diagram

LW 310A

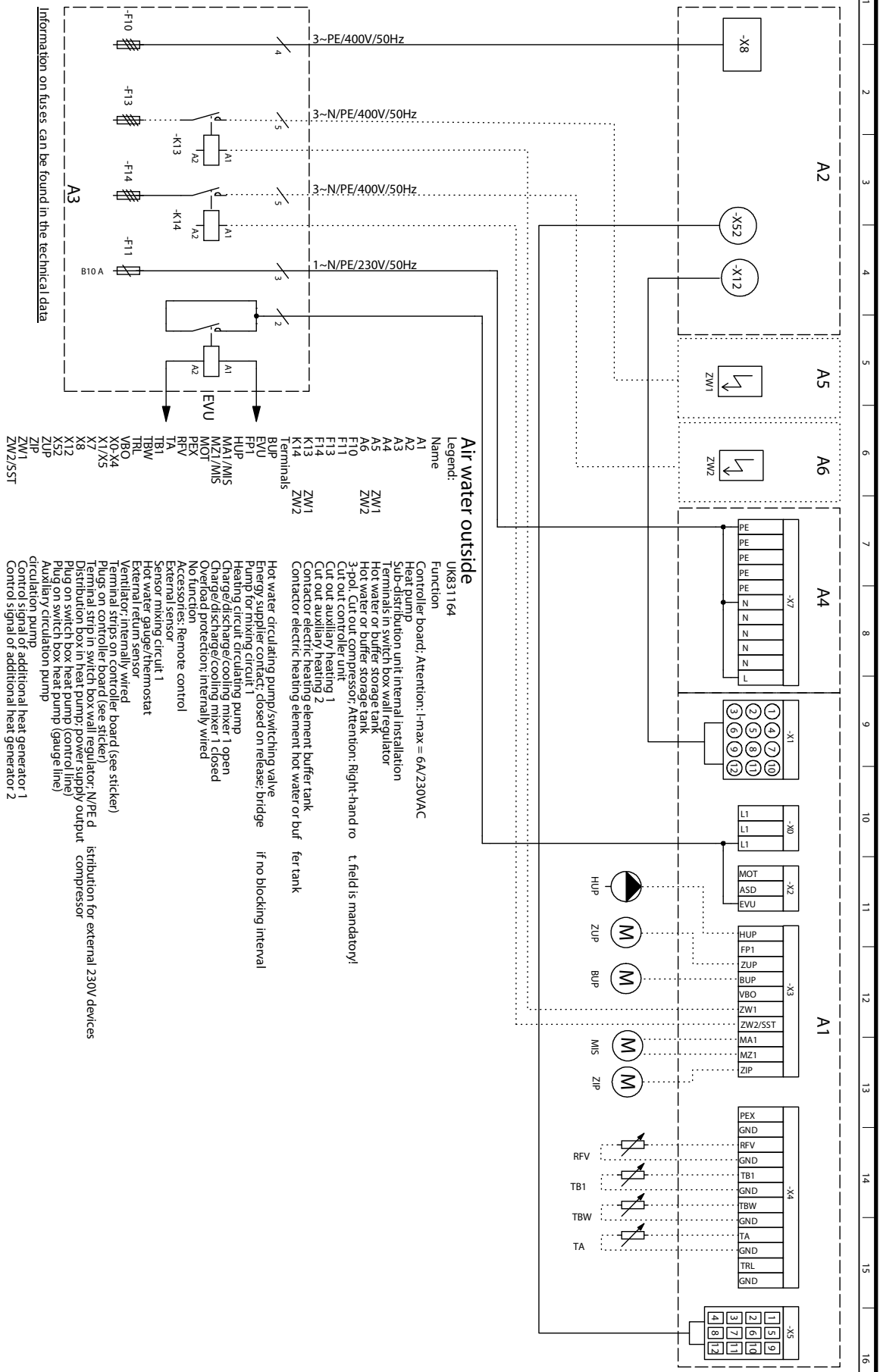



LW 71A – LW 81A

Circuit diagram 1/2

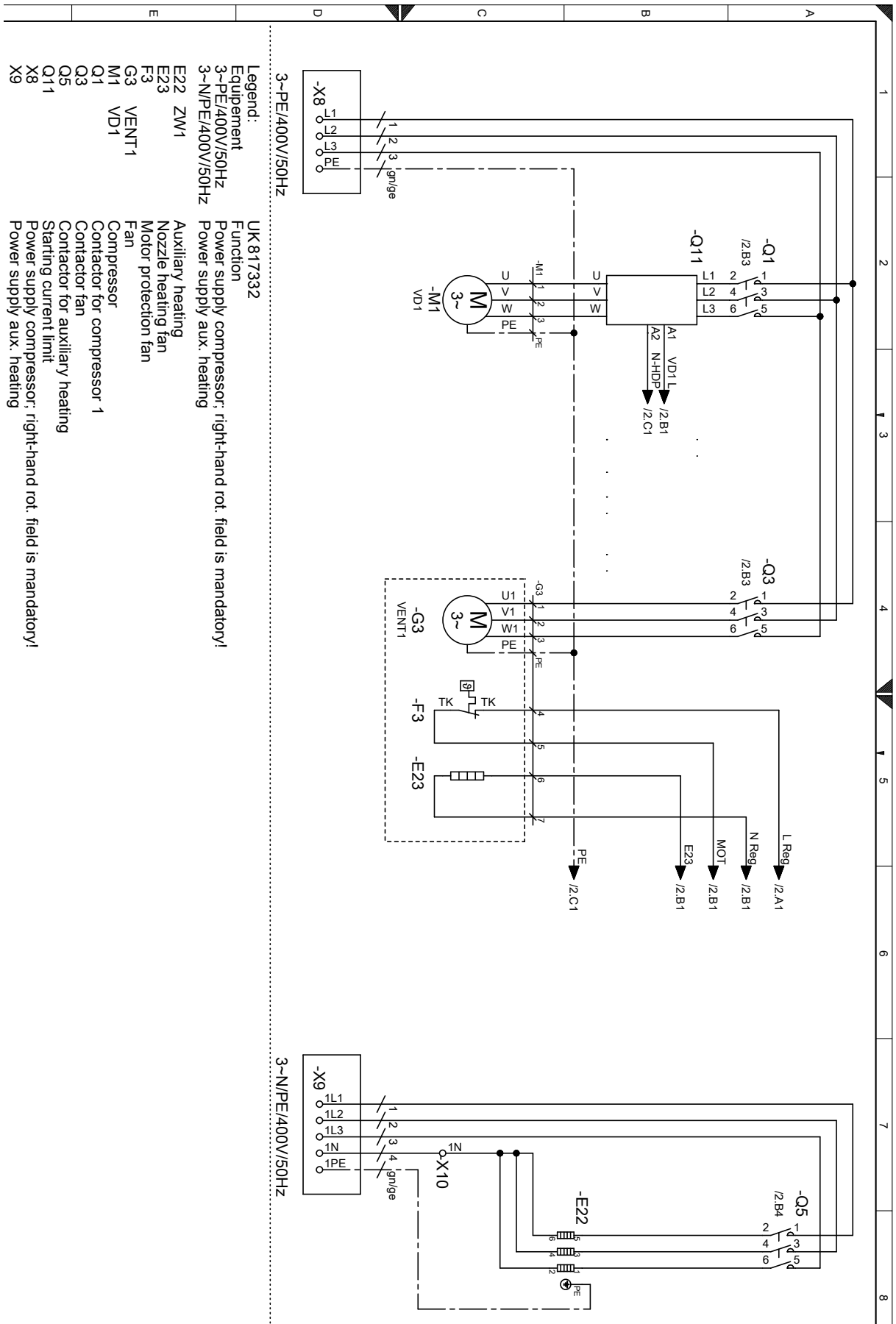

- Legend:**
- UK 817332 Function
 - Equipment 3-PE/400V/50Hz Power supply compressor: right-hand rot. field is mandatory!
 - 3-N/PE/400V/50Hz Power supply aux. heating
 - E22 ZW1 Auxiliary heating
 - E23 Nozzle heating fan
 - F3 Motor protection fan
 - G3 Fan
 - M1 Compressor
 - Q1 Contactor for compressor 1
 - Q3 Contactor fan
 - Q5 Contactor for auxiliary heating
 - Q11 Starting current limit
 - X8 Power supply compressor: right-hand rot. field is mandatory!
 - X9 Power supply aux. heating



LW 71A – LW 81A

Circuit diagram 2/2

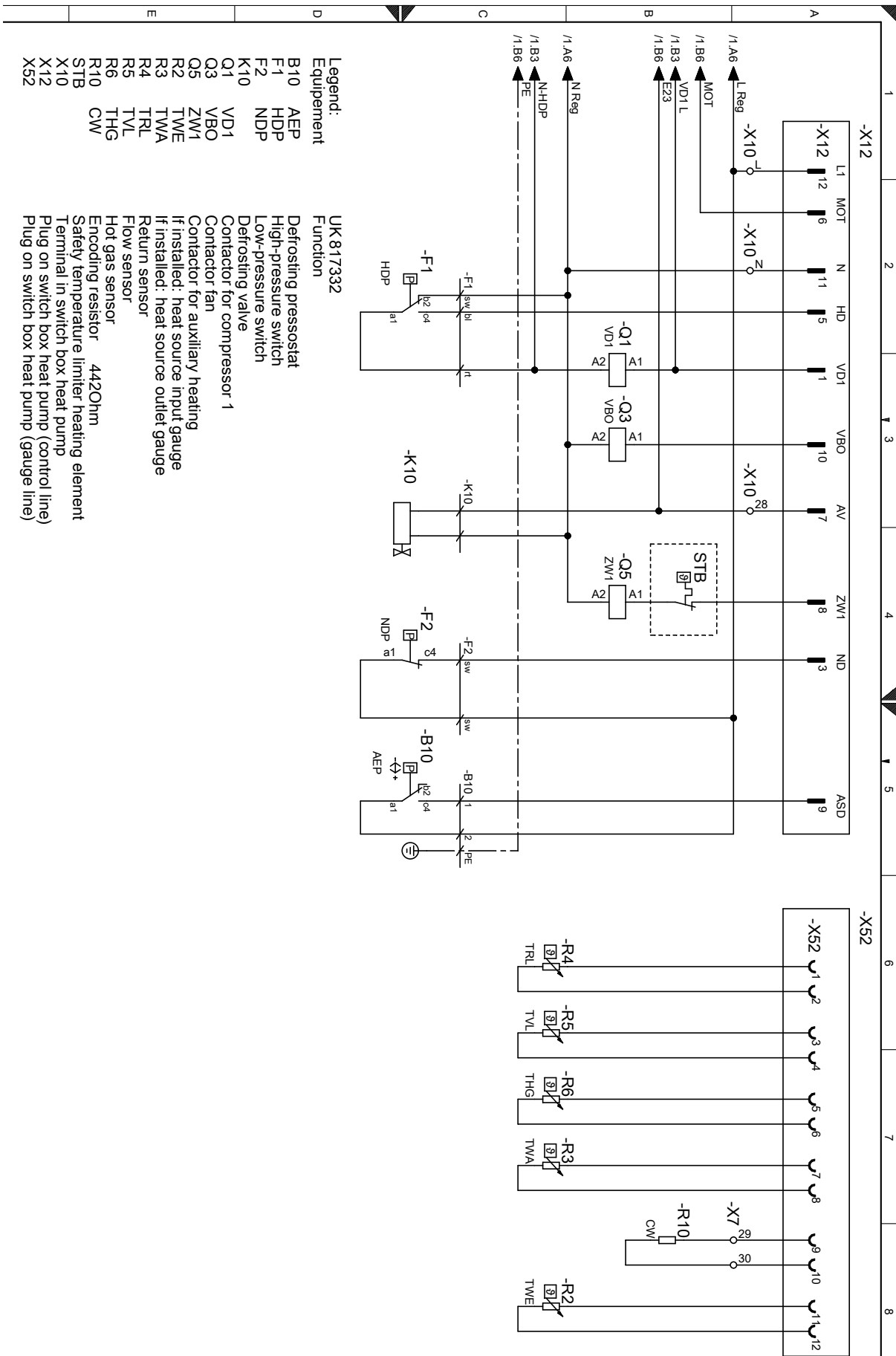



LW 101A – LW 121A

Circuit diagram 1/2

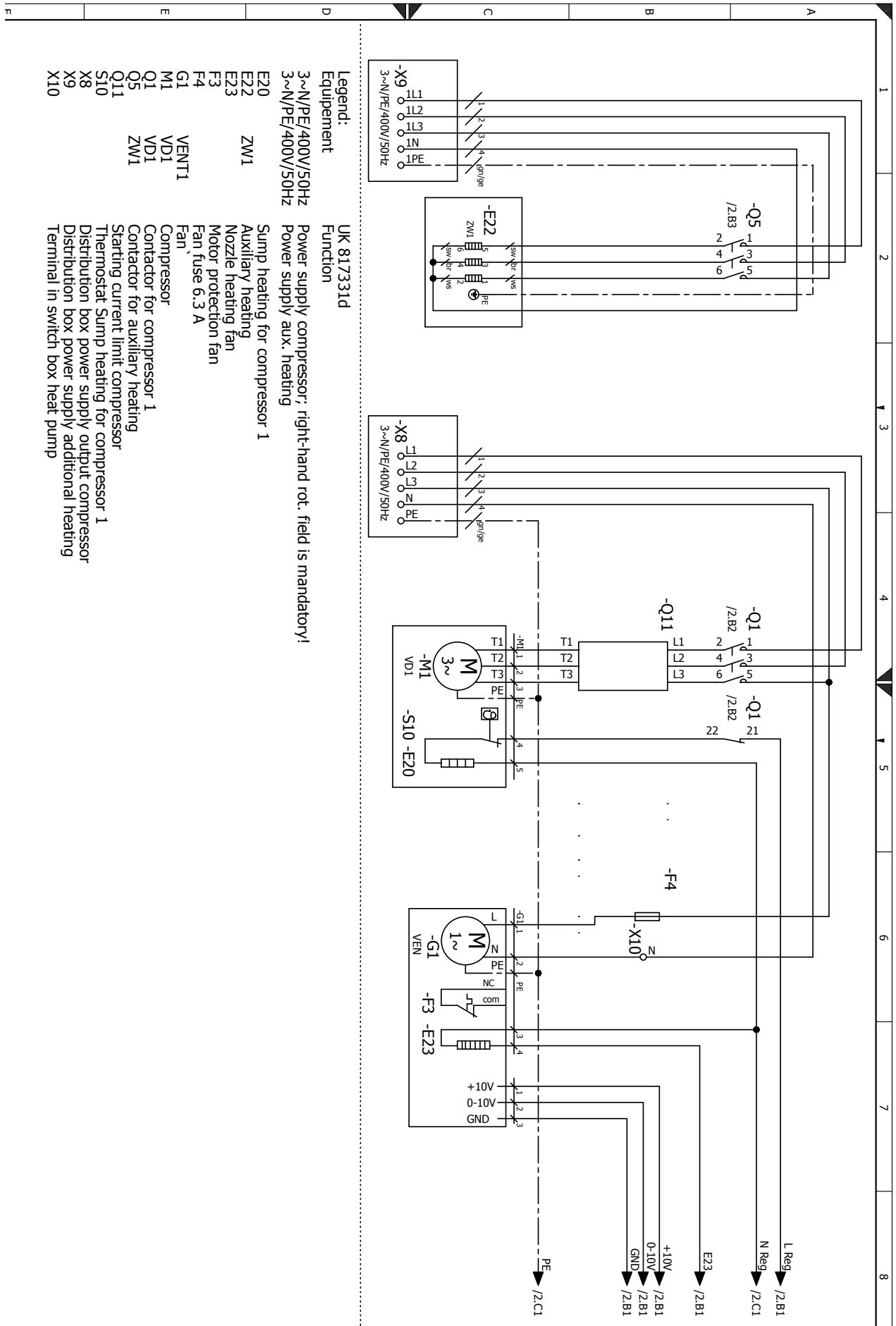



LW 101A – LW 121A

Circuit diagram 2/2

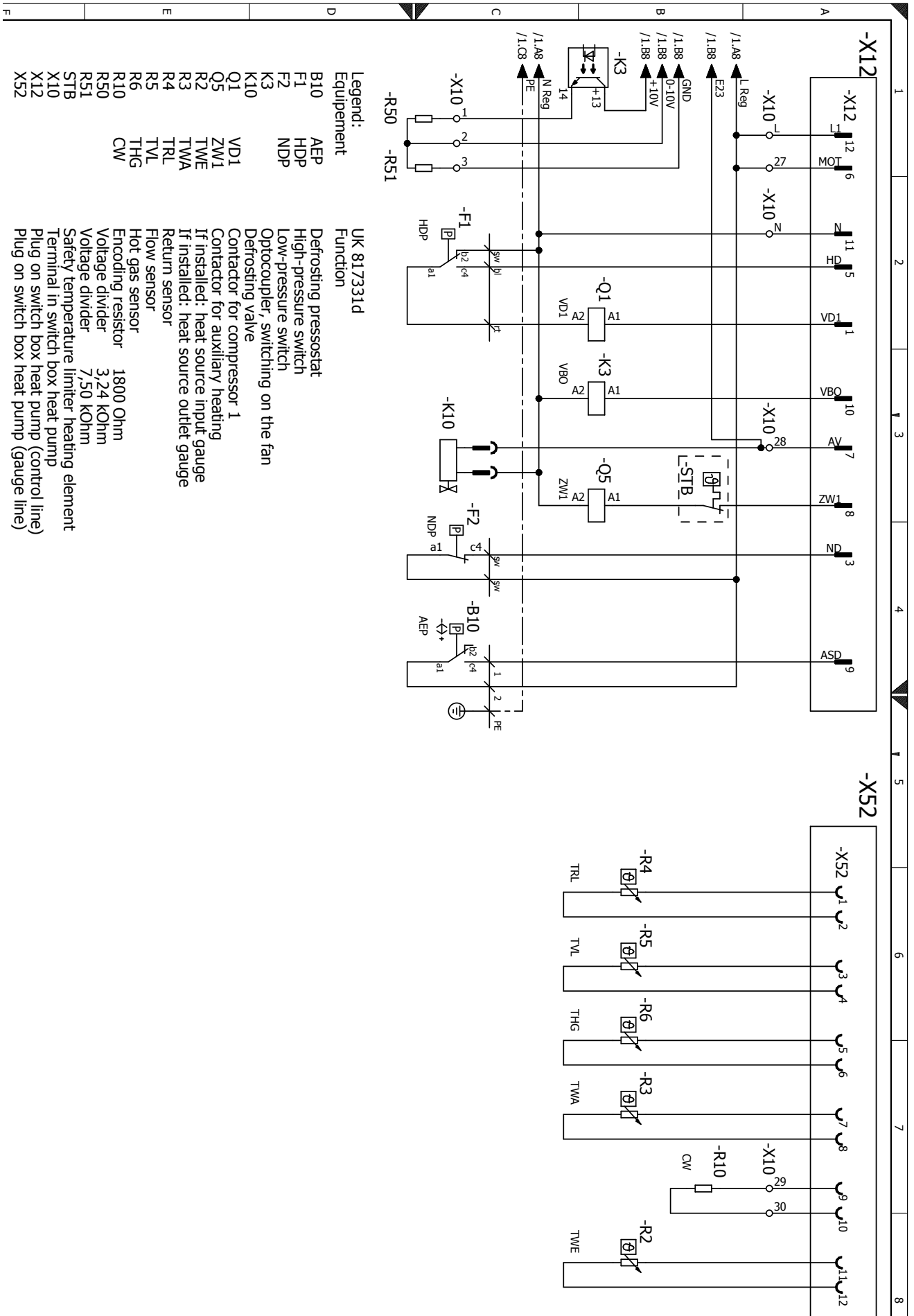

Legend:
 Equipment UK 817331d
 Function

- | | | |
|-----|-----|---|
| B10 | AEP | Defrosting pressostat |
| F1 | HDP | High-pressure switch |
| F2 | NDP | Low-pressure switch |
| K3 | | Optocoupler, switching on the fan |
| K10 | | Defrosting valve |
| Q1 | VD1 | Contactor for compressor 1 |
| Q2 | ZW1 | If installed: heat source input gauge |
| R2 | TWE | If installed: heat source outlet gauge |
| R3 | TWA | Return sensor |
| R4 | TRL | Flow sensor |
| R5 | TVL | Hot gas sensor |
| R6 | THG | Encoding resistor 1800 Ohm |
| R10 | CW | Voltage divider 3,24 KOhm |
| R50 | | Voltage divider 7,50 KOhm |
| R51 | | Safety temperature limiter heating element |
| STB | | Terminal in switch box heat pump |
| X10 | | Plug on switch box heat pump (control line) |
| X12 | | Plug on switch box heat pump (gauge line) |
| X52 | | |



LW 140A

Circuit diagram 1/2

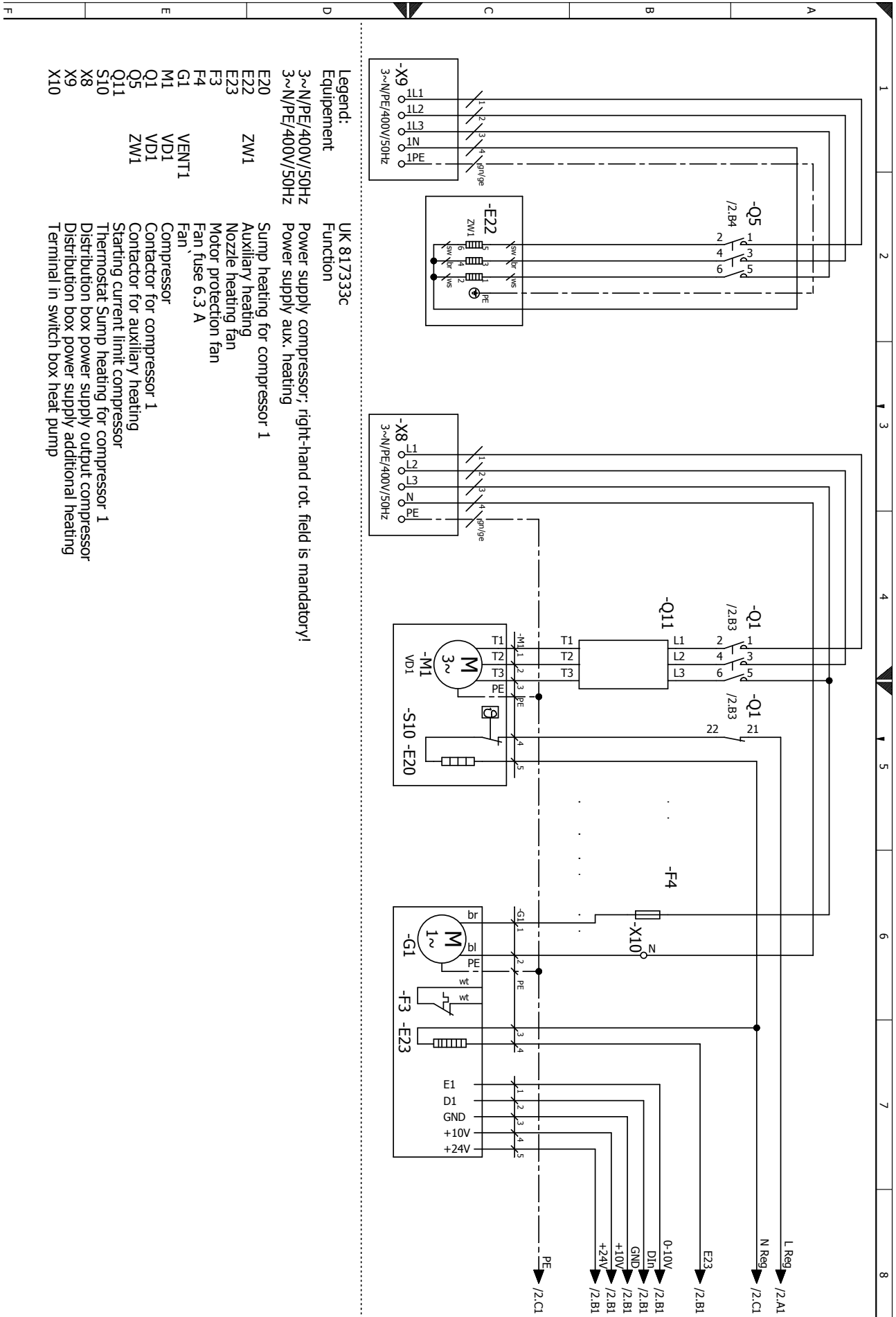



Circuit diagram 2/2

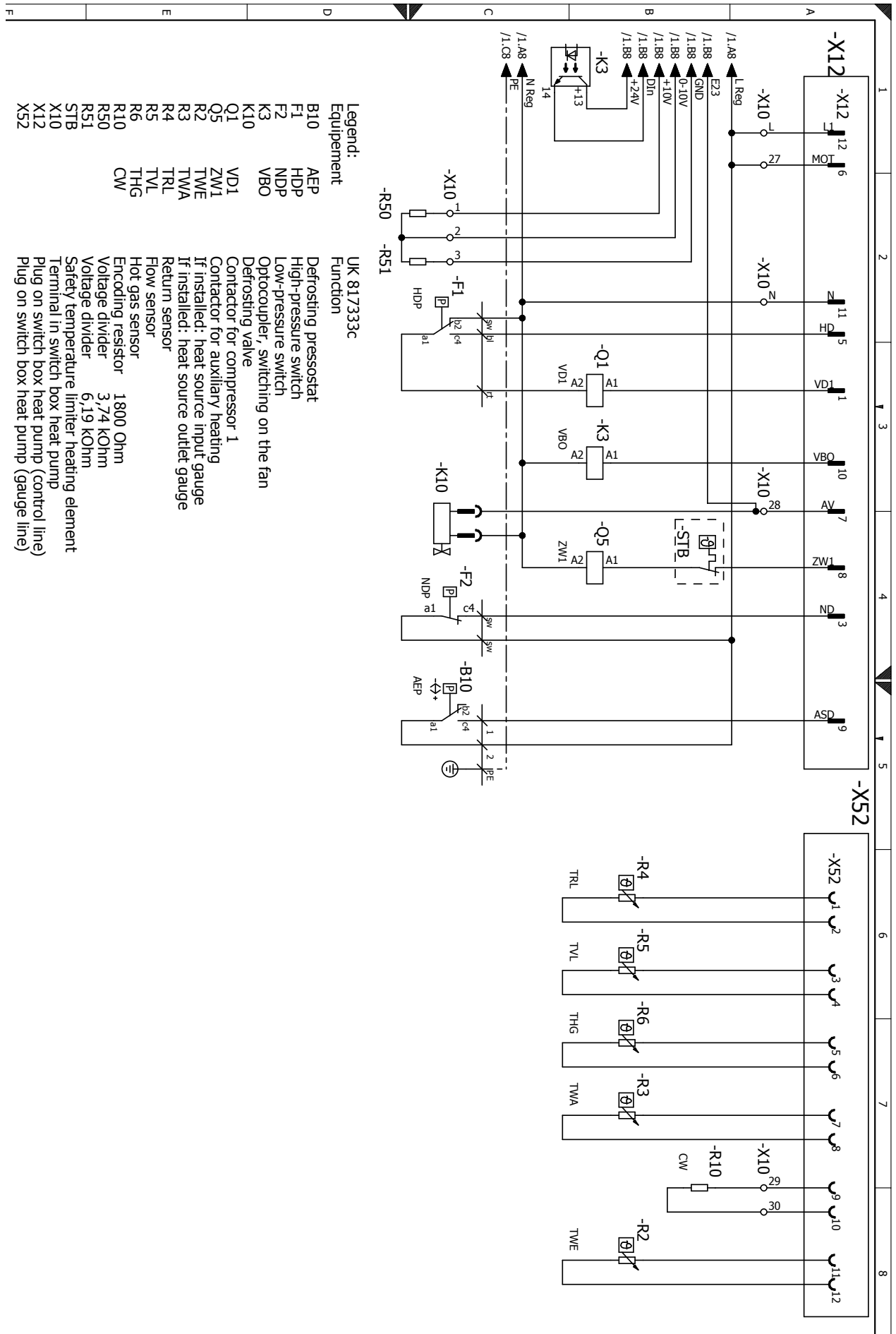

- Legend:**
- | | | |
|------------------|-------------------|---|
| Equipment | UK 817333C | Function |
| B10 | AEP | Defrosting pressostat |
| F1 | HDP | High-pressure switch |
| F2 | NDP | Low-pressure switch |
| K3 | VBO | Optocoupler, switching on the fan |
| K10 | | Defrosting valve |
| Q1 | VD1 | Contactor for compressor 1 |
| Q5 | ZW1 | Contactor for auxiliary heating |
| R2 | TW/E | If installed: heat source input gauge |
| R3 | TW/A | If installed: heat source outlet gauge |
| R4 | TRL | Return sensor |
| R5 | TVL | Flow sensor |
| R6 | THG | Hot gas sensor |
| R10 | | Encoding resistor 1800 Ohm |
| R50 | | Voltage divider 3,74 KOhm |
| R51 | | Voltage divider 6,19 KOhm |
| STB | | Safety temperature limiter heating element |
| X10 | | Terminal in switch box heat pump (control line) |
| X12 | | Plug on switch box heat pump (gauge line) |
| X52 | | |



LW 180A

Circuit diagram 1/2

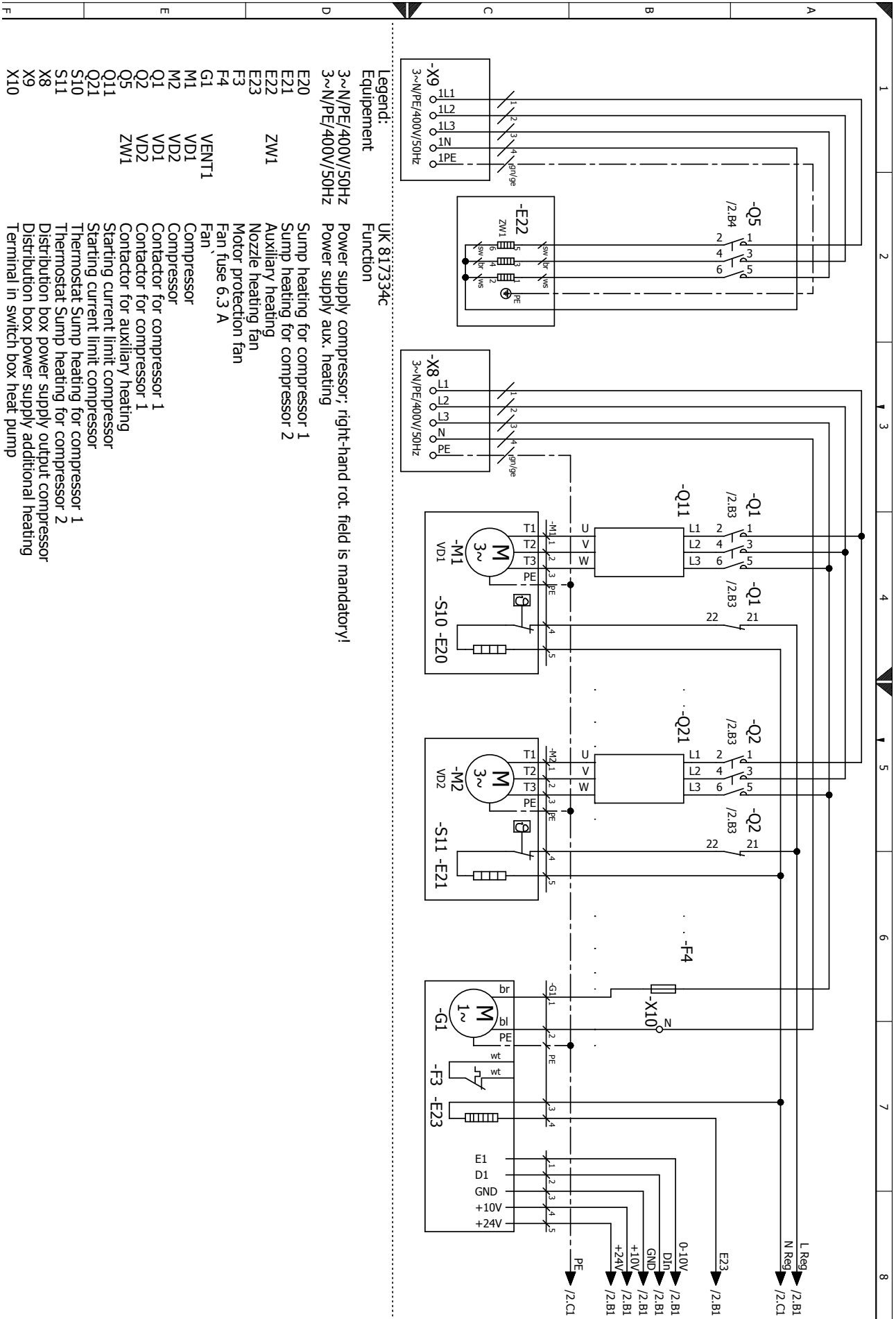



LW 180A

Circuit diagram 2/2

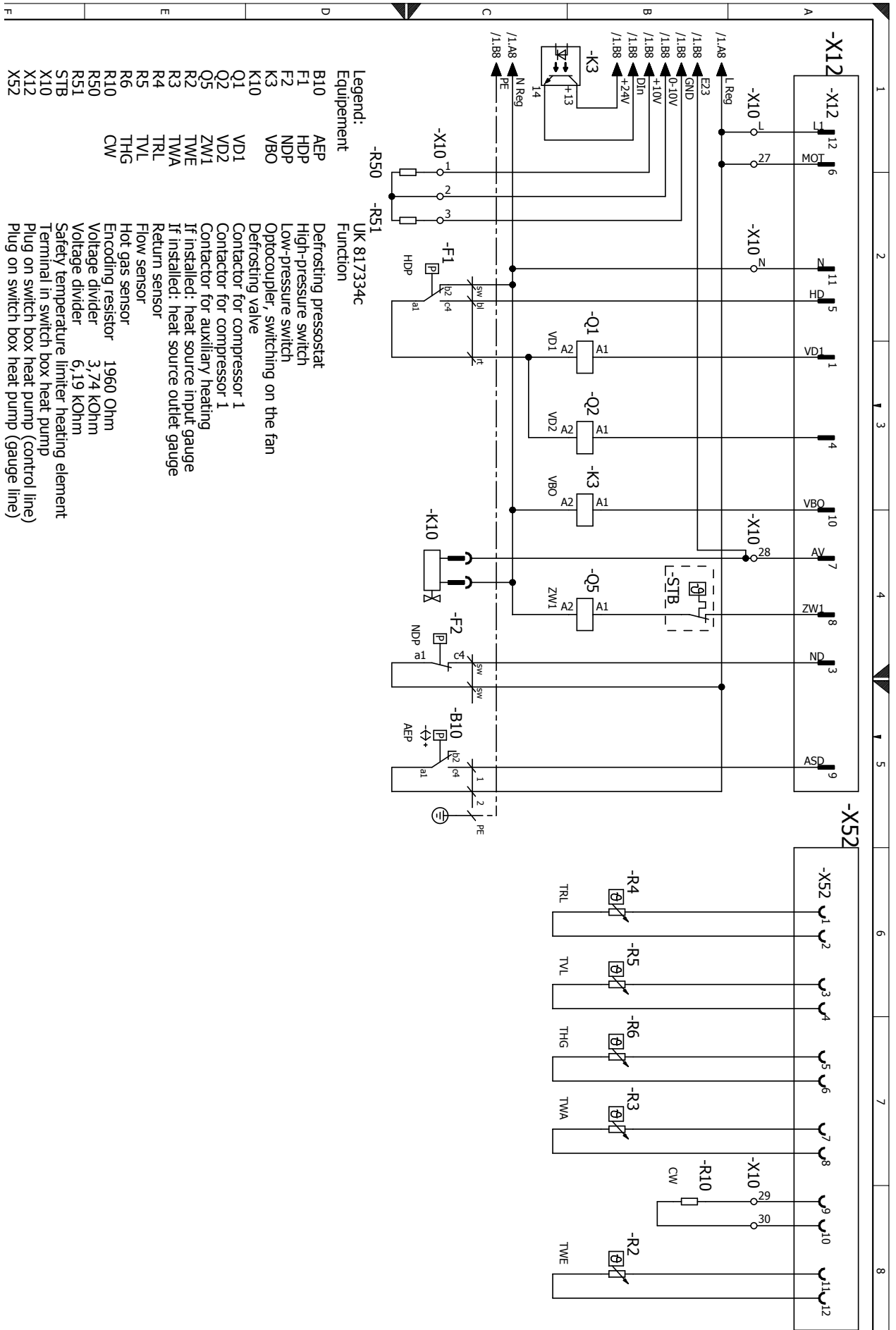

- Legend:**
- | | |
|------------------|---|
| Equipment | Function |
| B10 | UK 817334C |
| F1 | Defrosting pressostat |
| F2 | High-pressure switch |
| K3 | Low-pressure switch |
| K10 | Optocoupler, switching on the fan |
| Q1 | Defrosting valve |
| Q2 | Contactor for compressor 1 |
| Q5 | Contactor for compressor 1 |
| R2 | Contactor for auxiliary heating |
| R3 | If installed: heat source input gauge |
| R4 | If installed: heat source outlet gauge |
| R5 | Return sensor |
| R6 | Flow sensor |
| R10 | Hot gas sensor |
| R50 | Encoding resistor 1960 Ohm |
| R51 | Voltage divider 3,74 Kohm |
| STB | Voltage divider 6,19 Kohm |
| X10 | Safety temperature limiter heating element |
| X12 | Terminal in switch box heat pump |
| X52 | Plug on switch box heat pump (control line) |
| X52 | Plug on switch box heat pump (gauge line) |



LW 251A

Circuit diagram 1/3

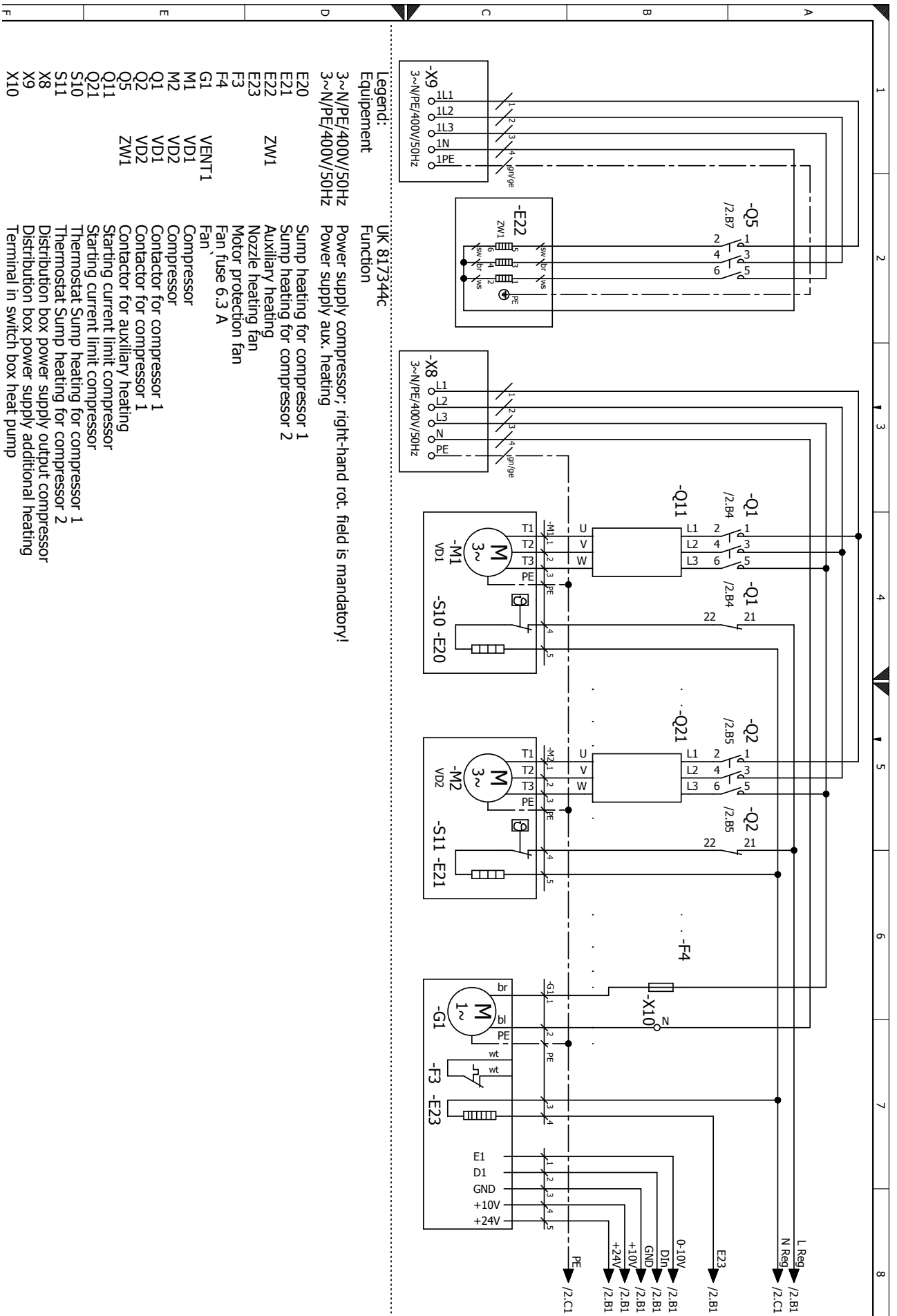



Circuit diagram 2/3

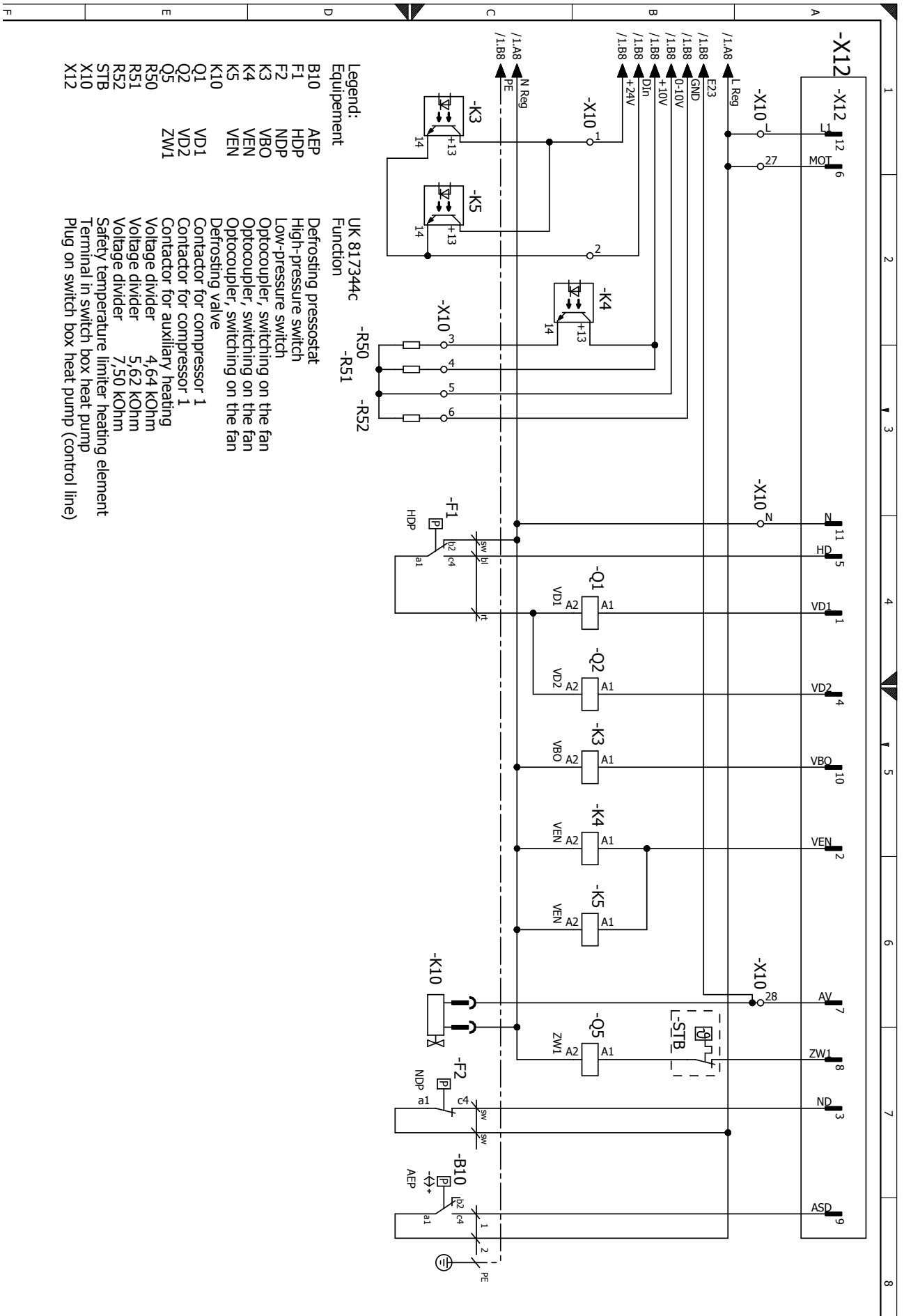

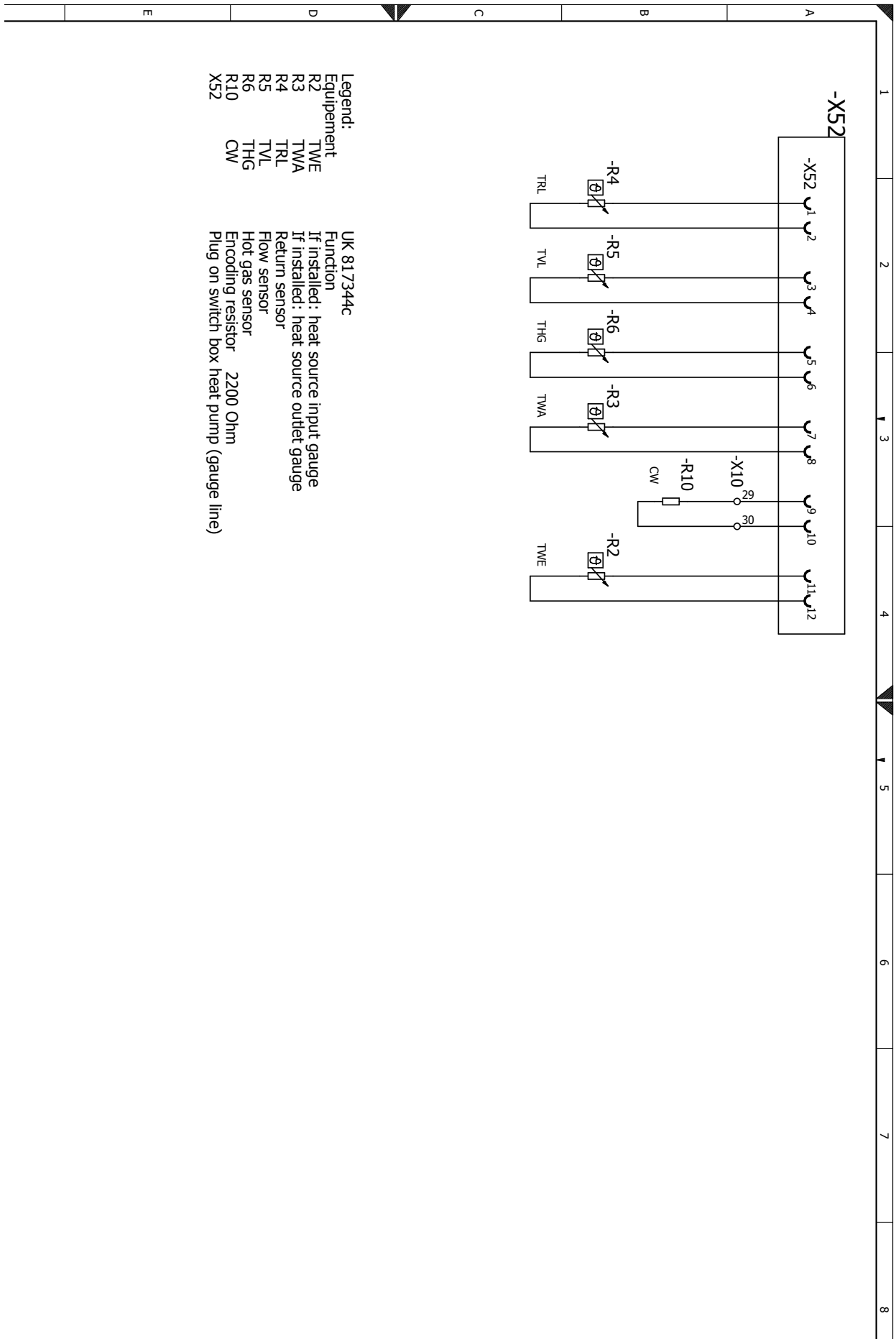



LW 310A

Circuit diagram 1/3

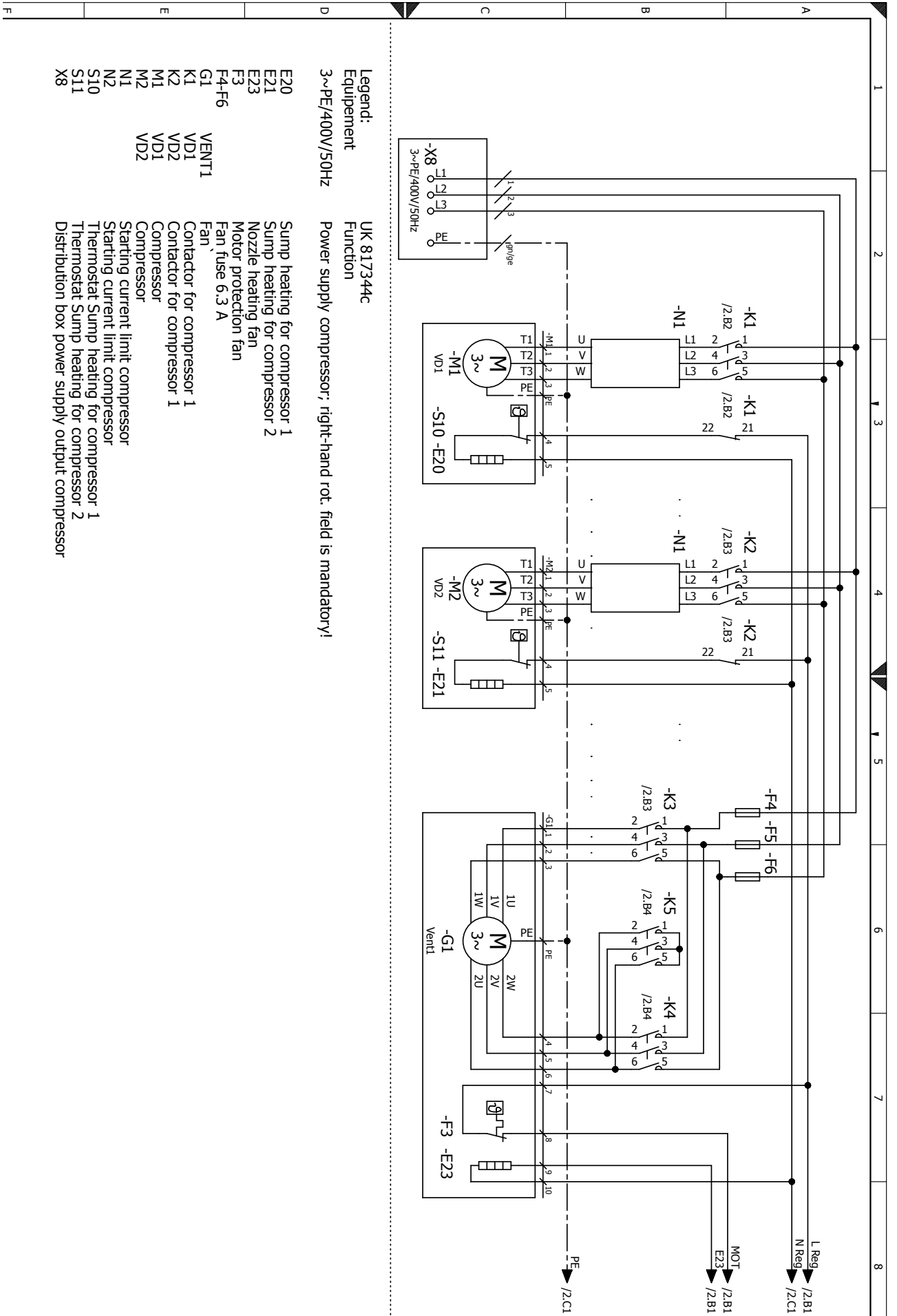

Legend:
Equipment UK 817344c
Function Power supply compressor, right-hand rot. field is mandatory!

- | | | |
|----------------|------------|--|
| 3~PE/400V/50Hz | UK 817344c | Power supply compressor, right-hand rot. field is mandatory! |
| E20 | | Sump heating for compressor 1 |
| E21 | | Sump heating for compressor 2 |
| E23 | | Nozzle heating fan |
| F3 | | Motor protection fan |
| F4-F6 | | Fan fuse 6.3 A |
| G1 | VENT1 | Fan |
| K1 | VD1 | Contactor for compressor 1 |
| K2 | VD2 | Contactor for compressor 1 |
| M1 | VD1 | Compressor |
| M2 | VD2 | Compressor |
| N1 | | Starting current limit compressor |
| N2 | | Starting current limit compressor |
| S10 | | Thermostat Sump heating for compressor 1 |
| S11 | | Thermostat Sump heating for compressor 2 |
| X8 | | Distribution box power supply output compressor |



LW 310A

Circuit diagram 2/3

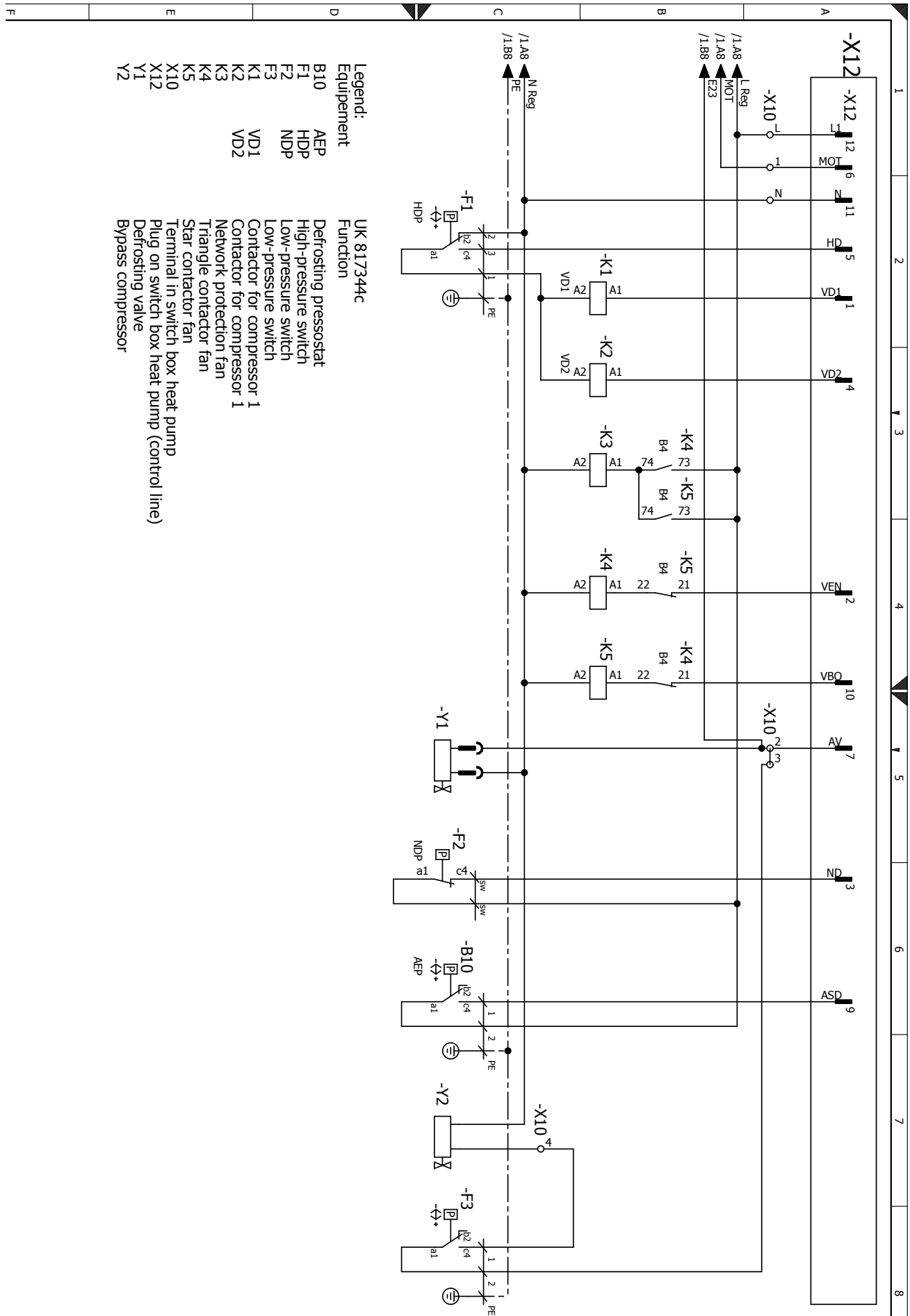

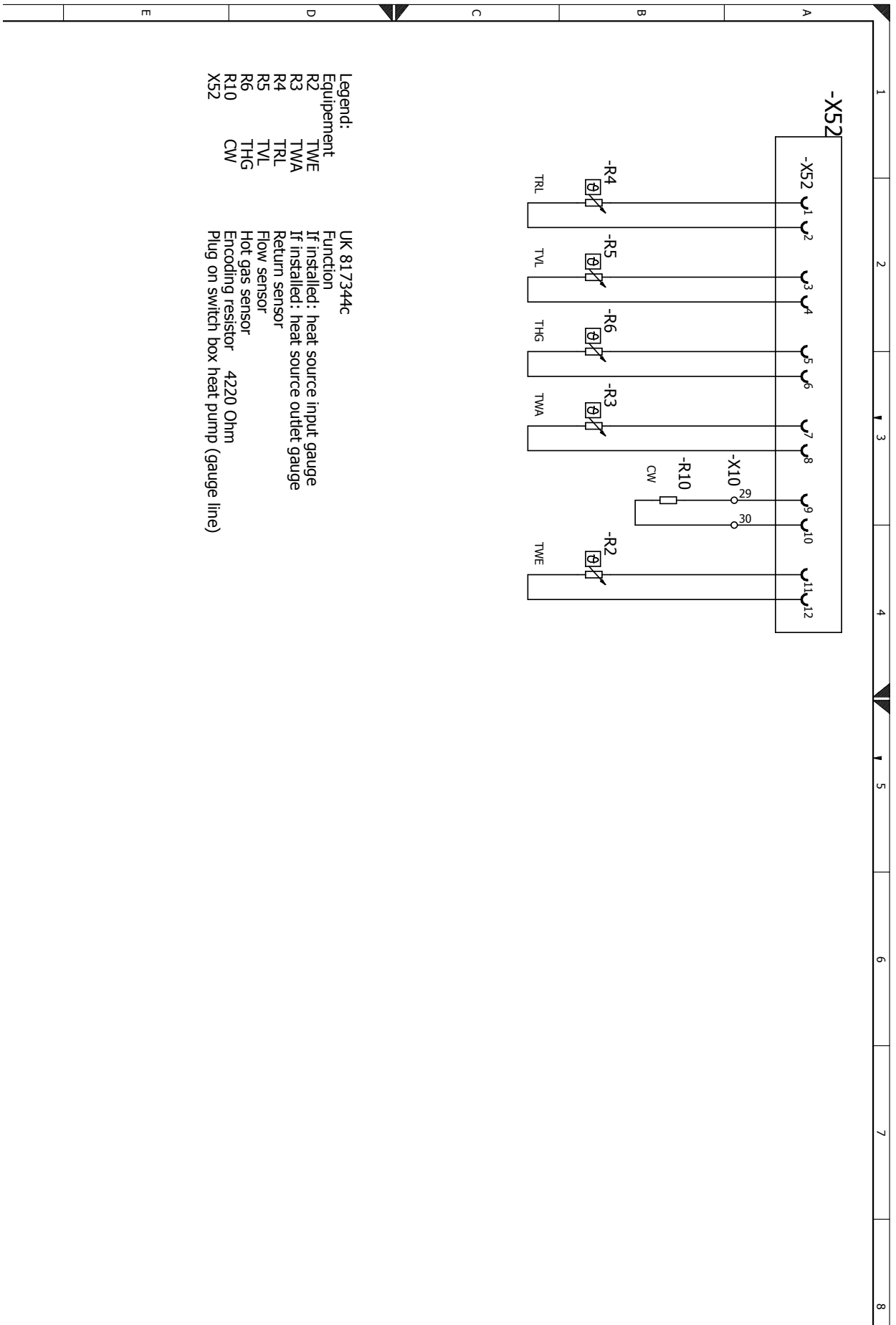



EC Declaration of Conformity in accordance with the EC Machinery Directive 2006/42/EC, Annex IIA



The undersigned confirms that the following designated device(s) as designed and marketed by us fulfill the standardized EC directives, the EC safety standards and the product-specific EC standards. In the event of modification of the device(s) without our approval, this declaration shall become invalid.

Designation of the device(s)

Heat Pump



Unit model	Order number	Item number 1	Item number 2
LW 71A-LUX 2.0	100540LUX02	100540	15029001
LW 81A-LUX 2.0	100541LUX02	100541	15029001
LW 101A-LUX 2.0	100542LUX02	100542	15029001
LW 121A-LUX 2.0	100543LUX02	100543	15029001
LW 140A-LUX 2.0	100544LUX02	100544	15029001
LW 180A-LUX 2.0*	100545LUX02	100545	15029001
LW 251A-LUX 2.0*	100546LUX02	100546	15029001
LW 310A-LUX 2.0*	100547LUX02	100547	15029001
LW 160H-AV-LUX 2.1	100625LUX01	100625	15077701
LW 71A-HT 1	100540HT102	100540	15031841
LW 81A-HT 1	100541HT102	100541	15031841
LW 101A-HT 2	100542HT202	100542	15031941
LW 121A-HT 2	100543HT202	100543	15031941
LW 140A-HT 2	100544HT202	100544	15031941
LW 180A-HT 2	100545HT202	100545	15031941

EC Directives

2006/42/EG 2009/125/EG
 2006/95/EG 2010/30/EU
 2004/108/EG
 *97/23/EG
 2011/65/EG

Standardized EN

EN 378 EN 349
 EN 60529 EN 60335-1/-2-40
 EN ISO 12100-1/2 EN 55014-1/-2
 EN ISO 13857 EN 61000-3-2/-3-3

* Pressure equipment component

Category II
 Module A1
 Designated position:
 TÜV-SÜD
 Industrie Service GmbH (Nr.:0036)

Company:

ait-deutschland GmbH
 Industrie Str. 3
 93359 Kasendorf
 Germany

Place, date: Kasendorf, 14.12.2015

Signature:

Jesper Stannow
 Head of Heating Development



ait-deutschland GmbH
Industriestraße 3
D-95359 Kasendorf

E info@alpha-innotec.de
W www.alpha-innotec.de



alpha innotec – an ait-deutschland GmbH brand